

Totally equimodular matrices: decomposition and triangulation

Mathieu Vallée¹

Université Libre de Bruxelles¹

Joint work with: Patrick Chervet and Roland Grappe

LIGM Seminar – Tuesday 13 April



Section 1

Context

Linear optimization problem

Let A be a matrix of size $m \times n$ and b be a vector.

Linear optimization problem

Let A be a matrix of size $m \times n$ and b be a vector.

Feasible set of $Ax \leq b$:

$$P = \{x : Ax \leq b\},$$

is a **polyhedron**.

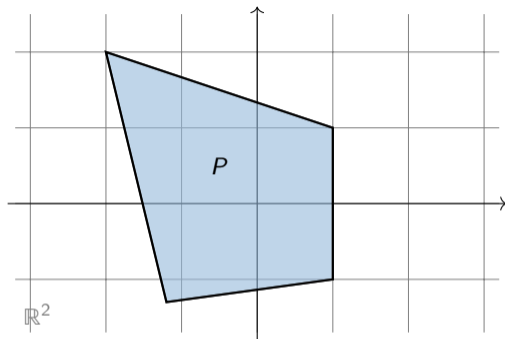

Linear optimization problem

Let A be a matrix of size $m \times n$ and b be a vector.

Feasible set of $Ax \leq b$:

$$P = \{x : Ax \leq b\},$$

is a **polyhedron**.

Linear optimization problem: for a vector $c \in \mathbb{Q}^n$

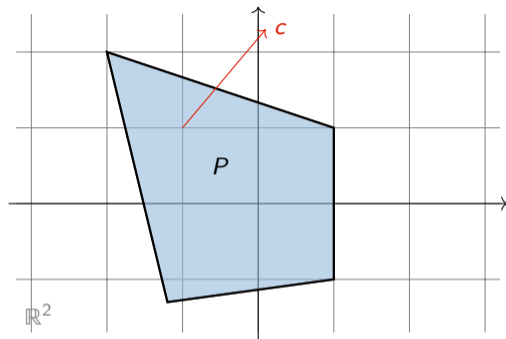

Linear optimization problem

Let A be a matrix of size $m \times n$ and b be a vector.

Feasible set of $Ax \leq b$:

$$P = \{x : Ax \leq b\},$$

is a **polyhedron**.

Linear optimization problem: for a vector $c \in \mathbb{Q}^n$

- **Primal:**

$$\max\{c^T x : Ax \leq b\}. \quad (1)$$

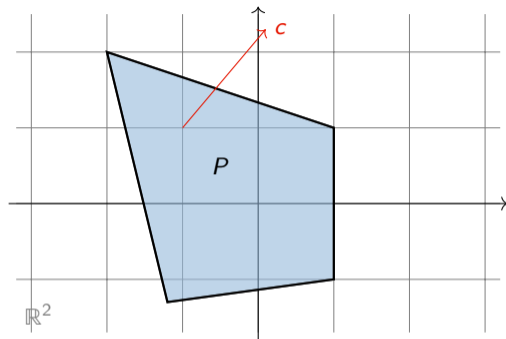

Linear optimization problem

Let A be a matrix of size $m \times n$ and b be a vector.

Feasible set of $Ax \leq b$:

$$P = \{x : Ax \leq b\},$$

is a **polyhedron**.

Linear optimization problem: for a vector $c \in \mathbb{Q}^n$

- Primal:

$$\max\{c^T x : Ax \leq b\}. \quad (1)$$

- Dual:

$$\min\{b^T y : A^T y = c, y \geq 0\}. \quad (2)$$

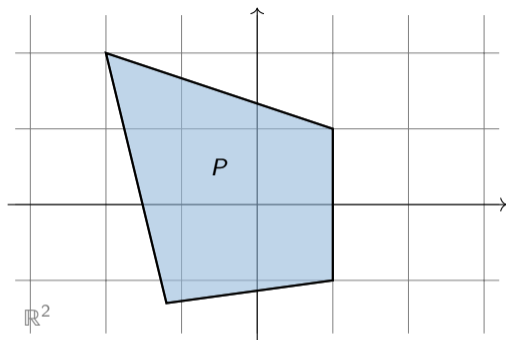

Linear optimization problem

Let A be a matrix of size $m \times n$ and b be a vector.

Feasible set of $Ax \leq b$:

$$P = \{x : Ax \leq b\},$$

is a **polyhedron**.

Linear optimization problem: for a vector $c \in \mathbb{Q}^n$

- Primal:

$$\max\{c^T x : Ax \leq b\}. \quad (1)$$

- Dual:

$$\min\{b^T y : A^T y = c, y \geq 0\}. \quad (2)$$

Theorem (Strong duality)

(1)=(2) when they are finite.

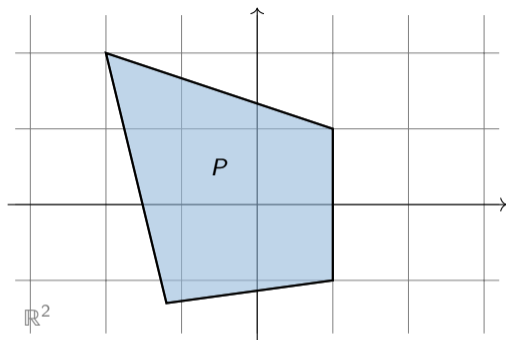

Linear optimization problem

Let A be a matrix of size $m \times n$ and b be a vector.

Feasible set of $Ax \leq b$:

$$P = \{x : Ax \leq b\},$$

is a **polyhedron**.

Linear optimization problem: for a vector $c \in \mathbb{Q}^n$

- Primal:

$$\max\{c^T x : Ax \leq b\}. \quad (1)$$

- Dual:

$$\min\{b^T y : A^T y = c, y \geq 0\}. \quad (2)$$

Theorem (Strong duality)

(1)=(2) when they are finite.

The **normal cone** of a face F of P is the set of vectors for which F is optimum.

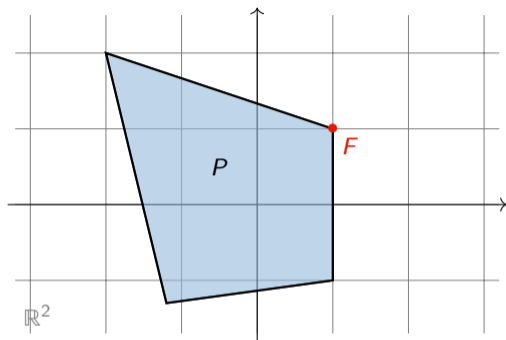

Linear optimization problem

Let A be a matrix of size $m \times n$ and b be a vector.

Feasible set of $Ax \leq b$:

$$P = \{x : Ax \leq b\},$$

is a **polyhedron**.

Linear optimization problem: for a vector $c \in \mathbb{Q}^n$

- Primal:

$$\max\{c^T x : Ax \leq b\}. \quad (1)$$

- Dual:

$$\min\{b^T y : A^T y = c, y \geq 0\}. \quad (2)$$

Theorem (Strong duality)

(1)=(2) when they are finite.

The **normal cone** of a face F of P is the set of vectors for which F is optimum.

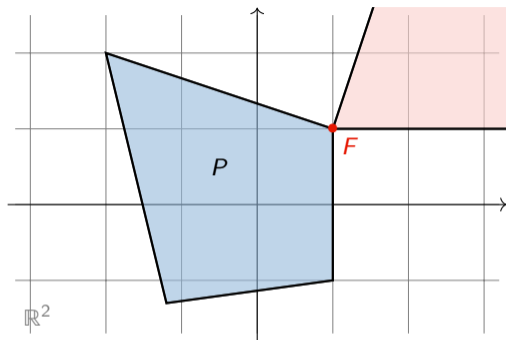

Linear optimization problem

Let A be a matrix of size $m \times n$ and b be a vector.

Feasible set of $Ax \leq b$:

$$P = \{x : Ax \leq b\},$$

is a **polyhedron**.

Linear optimization problem: for a vector $c \in \mathbb{Q}^n$

- Primal:

$$\max\{c^T x : Ax \leq b\}. \quad (1)$$

- Dual:

$$\min\{b^T y : A^T y = c, y \geq 0\}. \quad (2)$$

Theorem (Strong duality)

(1)=(2) when they are finite.

The **normal cone** of a face F of P is the set of vectors for which F is optimum.

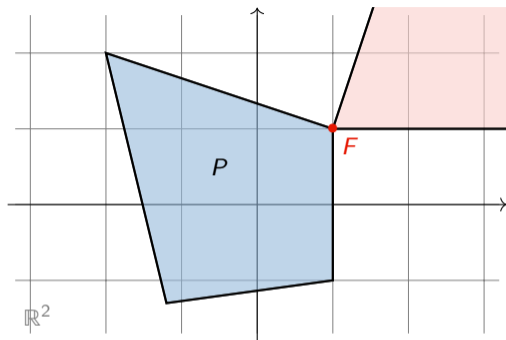

Fact: this cone is generated by the rows a_i of A with $a_i^T x = b_i$, for every $x \in F$. = **active rows**

Linear optimization problem

Let A be a matrix of size $m \times n$ and b be a vector.

Feasible set of $Ax \leq b$:

$$P = \{x : Ax \leq b\},$$

is a **polyhedron**.

Linear optimization problem: for a vector $c \in \mathbb{Q}^n$

- Primal:

$$\max\{c^T x : Ax \leq b\}. \quad (1)$$

- Dual:

$$\min\{b^T y : A^T y = c, y \geq 0\}. \quad (2)$$

Theorem (Strong duality)

(1)=(2) when they are finite.

The **normal cone** of a face F of P is the set of vectors for which F is optimum.

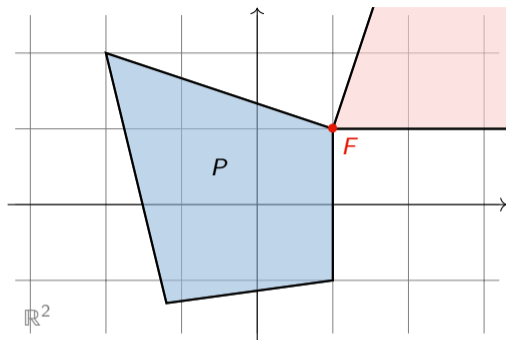

Fact: this cone is generated by the rows a_i of A with $a_i^T x = b_i$, for every $x \in F$. = **active rows**

Complementary slackness: an optimal solution to (2) is given by taking $y_i > 0$ only at the active rows.

Linear optimization problem

Let A be a matrix of size $m \times n$ and b be a vector.

Feasible set of $Ax \leq b$:

$$P = \{x : Ax \leq b\},$$

is a **polyhedron**.

Linear optimization problem: for a vector $c \in \mathbb{Q}^n$

- Primal:

$$\max\{c^T x : Ax \leq b\}. \quad (1)$$

- Dual:

$$\min\{b^T y : A^T y = c, y \geq 0\}. \quad (2)$$

Theorem (Strong duality)

(1)=(2) when they are finite.

The **normal cone** of a face F of P is the set of vectors for which F is optimum.

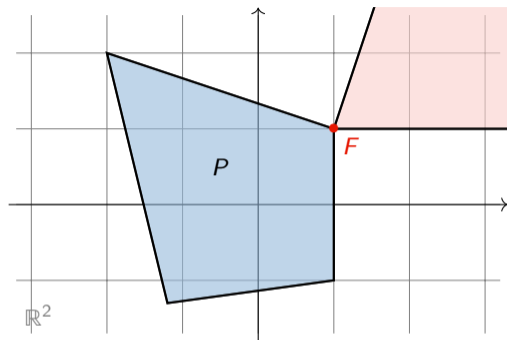

Fact: this cone is generated by the rows a_i of A with $a_i^T x = b_i$, for every $x \in F$. = **active rows**

Complementary slackness: an optimal solution to (2) is given by taking $y_i > 0$ only at the active rows.

Note: we can suppose c **integer**

Integer points \leftrightarrow discrete objects

Integer points \leftrightarrow discrete objects

Discrete optimization problem:

Integer points \leftrightarrow discrete objects

Discrete optimization problem:

$$\max\{c^\top x : Ax \leq b, x \in \mathbb{Z}^n\}. \quad (3)$$

Integer points \leftrightarrow discrete objects

Discrete optimization problem:

$$\max\{c^T x : Ax \leq b, x \in \mathbb{Z}^n\}. \quad (3)$$

$$\min\{b^T y : A^T y = c, y \geq 0\}. \quad (4)$$

Integer points \leftrightarrow discrete objects

Discrete optimization problem:

$$\max\{c^\top x : Ax \leq b, x \in \mathbb{Z}^n\}. \quad (3)$$

$$\min\{b^\top y : A^\top y = c, y \geq 0\}. \quad (4)$$

Question

When does (4) has an integer optimal solution?

Integer points \leftrightarrow discrete objects

Discrete optimization problem:

$$\max\{c^\top x : Ax \leq b, x \in \mathbb{Z}^n\}. \quad (3)$$

$$\min\{b^\top y : A^\top y = c, y \geq 0\}. \quad (4)$$

Question

When does (4) has an integer optimal solution?

\rightarrow **combinatorial MinMax Theorems.**

Integer points \leftrightarrow discrete objects

Discrete optimization problem:

A system $Ax \leq b$ is:

$$\max\{c^T x : Ax \leq b, x \in \mathbb{Z}^n\}. \quad (3)$$

$$\min\{b^T y : A^T y = c, y \geq 0\}. \quad (4)$$

Question

When does (4) has an integer optimal solution?

\rightarrow **combinatorial MinMax Theorems.**

Integer points \leftrightarrow discrete objects

Discrete optimization problem:

$$\max\{c^T x : Ax \leq b, x \in \mathbb{Z}^n\}. \quad (3)$$

$$\min\{b^T y : A^T y = c, y \geq 0\}. \quad (4)$$

A system $Ax \leq b$ is:

- **Totally dual integral (TDI)** when $\forall c \in \mathbb{Z}^n$, (4) has an integer solution when it is finite.

Question

When does (4) has an integer optimal solution?

\rightarrow **combinatorial MinMax Theorems.**

Integer points \leftrightarrow discrete objects

Discrete optimization problem:

$$\max\{c^T x : Ax \leq b, x \in \mathbb{Z}^n\}. \quad (3)$$

$$\min\{b^T y : A^T y = c, y \geq 0\}. \quad (4)$$

A system $Ax \leq b$ is:

- **Totally dual integral (TDI)** when $\forall c \in \mathbb{Z}^n$, (4) has an integer solution when it is finite.
- **Box-TDI** when $Ax \leq b, u \leq x \leq v$ is TDI $\forall u, v \in \mathbb{Q}^n$.

Question

When does (4) has an integer optimal solution?

\rightarrow **combinatorial MinMax Theorems.**

Integer points \leftrightarrow discrete objects

Discrete optimization problem:

$$\max\{c^T x : Ax \leq b, x \in \mathbb{Z}^n\}. \quad (3)$$

$$\min\{b^T y : A^T y = c, y \geq 0\}. \quad (4)$$

A system $Ax \leq b$ is:

- **Totally dual integral (TDI)** when $\forall c \in \mathbb{Z}^n$, (4) has an integer solution when it is finite.
- **Box-TDI** when $Ax \leq b, u \leq x \leq v$ is TDI $\forall u, v \in \mathbb{Q}^n$.

Example: MaxFlow-MinCut (Ford, Fulkerson 56).

Question

When does (4) has an integer optimal solution?

\rightarrow **combinatorial MinMax Theorems.**

Integer points \leftrightarrow discrete objects

Discrete optimization problem:

$$\max\{c^T x : Ax \leq b, x \in \mathbb{Z}^n\}. \quad (3)$$

$$\min\{b^T y : A^T y = c, y \geq 0\}. \quad (4)$$

A system $Ax \leq b$ is:

- **Totally dual integral (TDI)** when $\forall c \in \mathbb{Z}^n$, (4) has an integer solution when it is finite.
- **Box-TDI** when $Ax \leq b, u \leq x \leq v$ is TDI $\forall u, v \in \mathbb{Q}^n$.

Example: MaxFlow-MinCut (Ford, Fulkerson 56).

Question

When does (4) has an integer optimal solution?

\rightarrow **combinatorial MinMax Theorems.**

Question

Which properties make $Ax \leq b$ TDI? Box-TDI?

Integer points \leftrightarrow discrete objects

Discrete optimization problem:

$$\max\{c^T x : Ax \leq b, x \in \mathbb{Z}^n\}. \quad (3)$$

$$\min\{b^T y : A^T y = c, y \geq 0\}. \quad (4)$$

A system $Ax \leq b$ is:

- **Totally dual integral (TDI)** when $\forall c \in \mathbb{Z}^n$, (4) has an integer solution when it is finite.
- **Box-TDI** when $Ax \leq b, u \leq x \leq v$ is TDI $\forall u, v \in \mathbb{Q}^n$.

Example: MaxFlow-MinCut (Ford, Fulkerson 56).

Question

When does (4) has an integer optimal solution?

\rightarrow **combinatorial MinMax Theorems.**

Question

Which properties make $Ax \leq b$ TDI? Box-TDI?

We will study each normal cone **individually.**

TDI-ness \rightarrow generate integer vectors of the normal cones

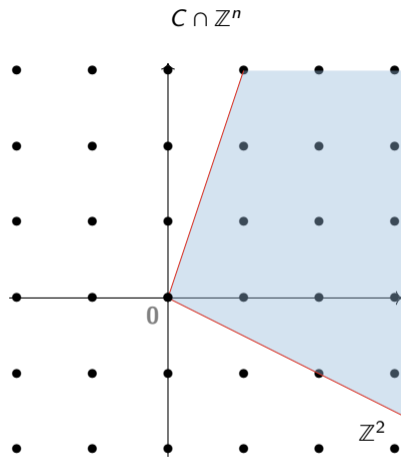

TDI-ness \rightarrow generate integer vectors of the normal cones

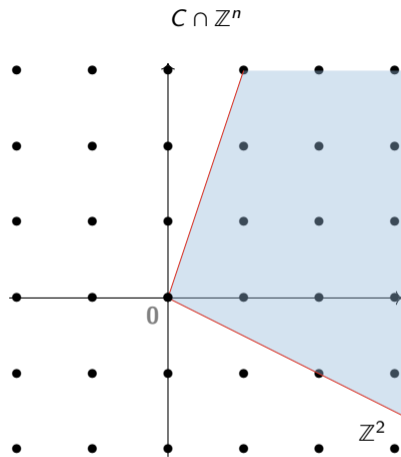

A **Hilbert basis element** of C is an integer vector of C which cannot be decomposed as the sum of two nonzero integer vectors of C .

TDI-ness \rightarrow generate integer vectors of the normal cones

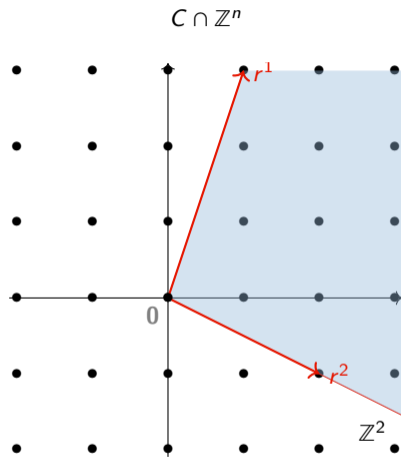

A **Hilbert basis element** of C is an integer vector of C which cannot be decomposed as the sum of two nonzero integer vectors of C .

TDI-ness \rightarrow generate integer vectors of the normal cones

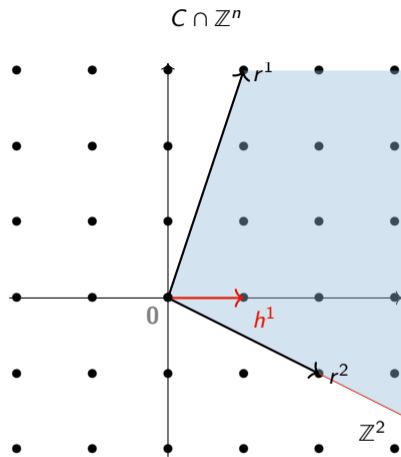

A **Hilbert basis element** of C is an integer vector of C which cannot be decomposed as the sum of two nonzero integer vectors of C .

TDI-ness \rightarrow generate integer vectors of the normal cones

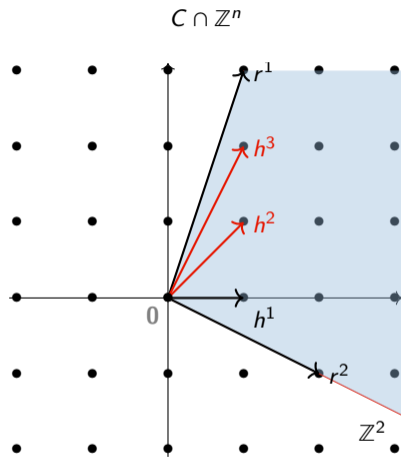

A **Hilbert basis element** of C is an integer vector of C which cannot be decomposed as the sum of two nonzero integer vectors of C .

TDI-ness \rightarrow generate integer vectors of the normal cones

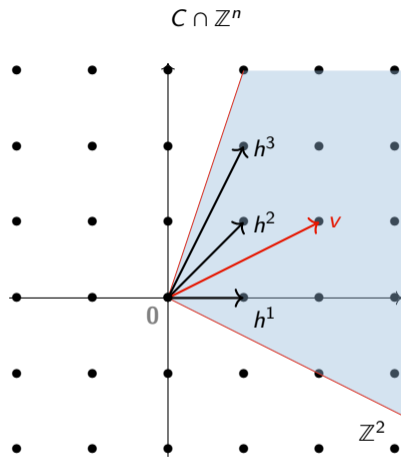

A **Hilbert basis element** of C is an integer vector of C which cannot be decomposed as the sum of two nonzero integer vectors of C .

TDI-ness \rightarrow generate integer vectors of the normal cones

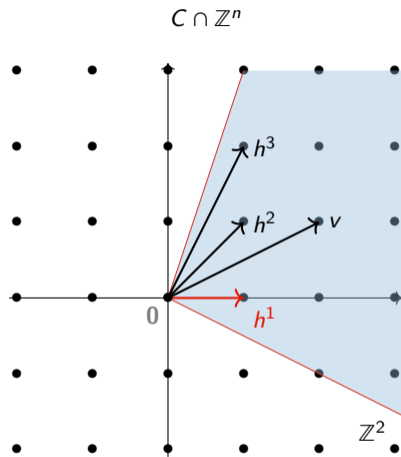

A **Hilbert basis element** of C is an integer vector of C which cannot be decomposed as the sum of two nonzero integer vectors of C .

TDI-ness \rightarrow generate integer vectors of the normal cones

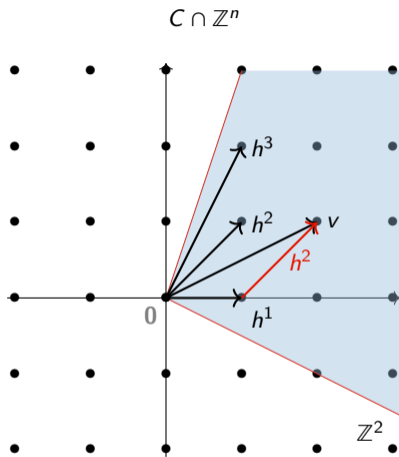

A **Hilbert basis element** of C is an integer vector of C which cannot be decomposed as the sum of two nonzero integer vectors of C .

TDI-ness \rightarrow generate integer vectors of the normal cones

Fact: The Hilbert basis $\mathbb{Z}_{\geq 0}$ -generates $C \cap \mathbb{Z}^n$.

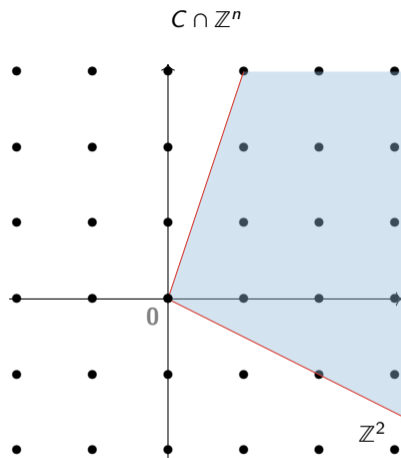

A **Hilbert basis element** of C is an integer vector of C which cannot be decomposed as the sum of two nonzero integer vectors of C .

TDI-ness \rightarrow generate integer vectors of the normal cones

Fact: The Hilbert basis $\mathbb{Z}_{\geq 0}$ -generates $C \cap \mathbb{Z}^n$.

Theorem (Schrijver, 1986)

A system $Ax \leq b$ is TDI if and only if for every face of the underlying polyhedron P , the set of active rows of F forms a Hilbert basis of the normal cone of F .

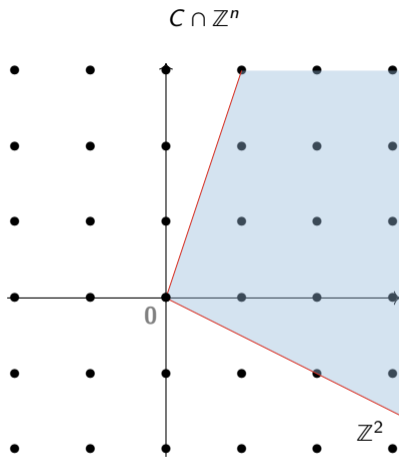

A **Hilbert basis element** of C is an integer vector of C which cannot be decomposed as the sum of two nonzero integer vectors of C .

TDI-ness \rightarrow generate integer vectors of the normal cones

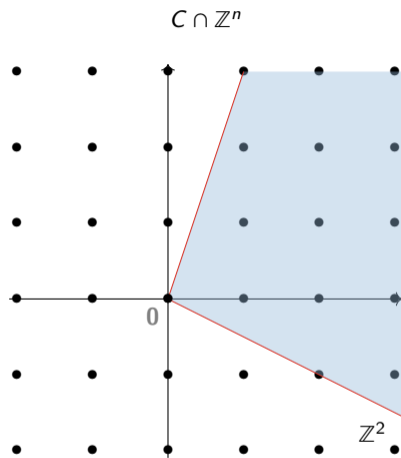

A **Hilbert basis element** of C is an integer vector of C which cannot be decomposed as the sum of two nonzero integer vectors of C .

Fact: The Hilbert basis $\mathbb{Z}_{\geq 0}$ -generates $C \cap \mathbb{Z}^n$.

Theorem (Schrijver, 1986)

A system $Ax \leq b$ is TDI if and only if for every face of the underlying polyhedron P , the set of active rows of F forms a Hilbert basis of the normal cone of F .

Theorem (Schrijver, 1981)

Every polyhedron can be described by a TDI system.

TDI-ness \rightarrow generate integer vectors of the normal cones

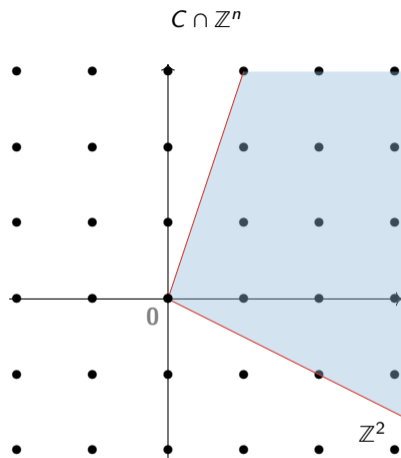

A **Hilbert basis element** of C is an integer vector of C which cannot be decomposed as the sum of two nonzero integer vectors of C .

Fact: The Hilbert basis $\mathbb{Z}_{\geq 0}$ -generates $C \cap \mathbb{Z}^n$.

Theorem (Schrijver, 1986)

A system $Ax \leq b$ is TDI if and only if for every face of the underlying polyhedron P , the set of active rows of F forms a Hilbert basis of the normal cone of F .

Theorem (Schrijver, 1981)

Every polyhedron can be described by a TDI system.

Proof: $Ax \leq b \rightarrow A'x \leq b'$ (TDI) up to adding a Hilbert basis of each normal cone as new inequalities, with well chosen b'_i for every new rows a'_i .

TDI-ness \rightarrow generate integer vectors of the normal cones

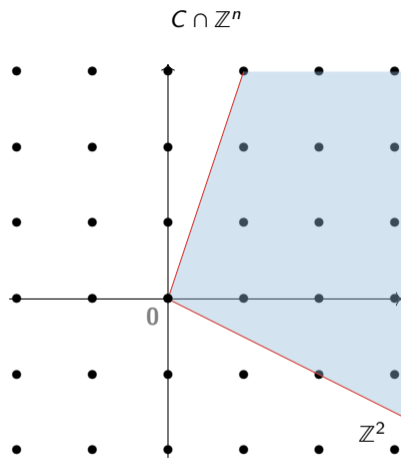

A **Hilbert basis element** of C is an integer vector of C which cannot be decomposed as the sum of two nonzero integer vectors of C .

Fact: The Hilbert basis $\mathbb{Z}_{\geq 0}$ -generates $C \cap \mathbb{Z}^n$.

Theorem (Schrijver, 1986)

A system $Ax \leq b$ is TDI if and only if for every face of the underlying polyhedron P , the set of active rows of F forms a Hilbert basis of the normal cone of F .

Theorem (Schrijver, 1981)

Every polyhedron can be described by a TDI system.

Proof: $Ax \leq b \rightarrow A'x \leq b'$ (TDI) up to adding a Hilbert basis of each normal cone as new inequalities, with well chosen b'_i for every new rows a'_i .

Question

How about the box-TDI property?

TDI-ness \rightarrow generate integer vectors of the normal cones

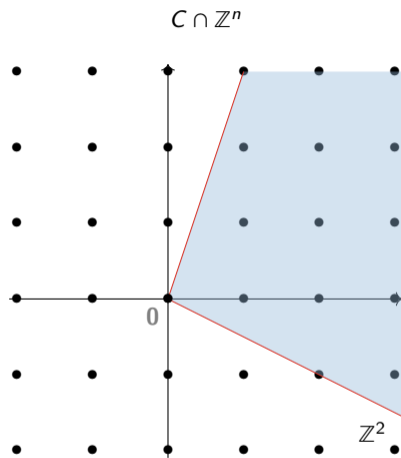

A **Hilbert basis element** of C is an integer vector of C which cannot be decomposed as the sum of two nonzero integer vectors of C .

Fact: The Hilbert basis $\mathbb{Z}_{\geq 0}$ -generates $C \cap \mathbb{Z}^n$.

Theorem (Schrijver, 1986)

A system $Ax \leq b$ is TDI if and only if for every face of the underlying polyhedron P , the set of active rows of F forms a Hilbert basis of the normal cone of F .

Theorem (Schrijver, 1981)

Every polyhedron can be described by a TDI system.

Proof: $Ax \leq b \rightarrow A'x \leq b'$ (TDI) up to adding a Hilbert basis of each normal cone as new inequalities, with well chosen b'_i for every new rows a'_i .

Question

How about the box-TDI property?

Fact: Not every polyhedron can be described by a box-TDI system. If it can: **Box-TDI polyhedron**.

Section 2

Totally equimodular matrices: decomposition

Box-TDIness from the structure of the matrix A

Box-TDIness from the structure of the matrix A

Let $A \in \mathbb{Z}^{r \times n}$ be a matrix.

$A =$



Box-TDIness from the structure of the matrix A

Let $A \in \mathbb{Z}^{r \times n}$ be a matrix.

Totally unimodular (TU) matrix:

- All the nonzero subdeterminants of A are ± 1 .

$A =$



Box-TDIness from the structure of the matrix A

Let $A \in \mathbb{Z}^{r \times n}$ be a matrix.

Totally unimodular (TU) matrix:

- All the nonzero subdeterminants of A are ± 1 .

$$A = \left[\begin{array}{|c|c|} \hline & \\ \hline \end{array} \right]$$

Box-TDIness from the structure of the matrix A

Let $A \in \mathbb{Z}^{r \times n}$ be a matrix.

Totally unimodular (TU) matrix:

- All the nonzero subdeterminants of A are ± 1 .

$$A = \begin{bmatrix} & \square & & \square \\ & \square & & \square \\ & & & \end{bmatrix}$$

Box-TDIness from the structure of the matrix A

Let $A \in \mathbb{Z}^{r \times n}$ be a matrix.

Totally unimodular (TU) matrix:

- All the nonzero subdeterminants of A are ± 1 .

Theorem (Hoffman, Kruskal, 1956)

A TU $\Leftrightarrow \forall b \in \mathbb{Z}^m, Ax \leq b$ is box-TDI.

$A =$

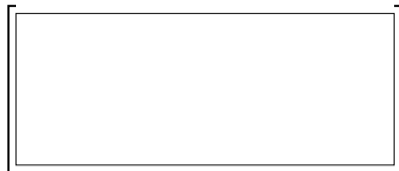

Box-TDIness from the structure of the matrix A

Let $A \in \mathbb{Z}^{r \times n}$ be a matrix.

Totally unimodular (TU) matrix:

- All the nonzero subdeterminants of A are ± 1 .

Theorem (Hoffman, Kruskal, 1956)

A TU $\Leftrightarrow \forall b \in \mathbb{Z}^m, Ax \leq b$ is box-TDI.

\rightarrow incidence matrix of a network is TU \Rightarrow MaxFlow-MinCut.

$A =$



Box-TDIness from the structure of the matrix A

Let $A \in \mathbb{Z}^{r \times n}$ be a matrix.

Totally unimodular (TU) matrix:

- All the nonzero subdeterminants of A are ± 1 .

Theorem (Hoffman, Kruskal, 1956)

A TU $\Leftrightarrow \forall b \in \mathbb{Z}^m, Ax \leq b$ is box-TDI.

\rightarrow incidence matrix of a network is TU \Rightarrow MaxFlow-MinCut.

Equimodular matrix:

- A has full row rank r ,
- All the $r \times r$ nonzero subdeterminants of A have the **same absolute value**.

$A =$



Box-TDIness from the structure of the matrix A

Let $A \in \mathbb{Z}^{r \times n}$ be a matrix.

Totally unimodular (TU) matrix:

- All the nonzero subdeterminants of A are ± 1 .

Theorem (Hoffman, Kruskal, 1956)

A TU $\Leftrightarrow \forall b \in \mathbb{Z}^m, Ax \leq b$ is box-TDI.

\rightarrow incidence matrix of a network is TU \Rightarrow MaxFlow-MinCut.

Equimodular matrix:

- A has full row rank r ,
- All the $r \times r$ nonzero subdeterminants of A have the same absolute value.

$$A = \left[\begin{array}{|c|c|} \hline & \\ \hline \end{array} \right]$$

-4

Box-TDIness from the structure of the matrix A

Let $A \in \mathbb{Z}^{r \times n}$ be a matrix.

Totally unimodular (TU) matrix:

- All the nonzero subdeterminants of A are ± 1 .

Theorem (Hoffman, Kruskal, 1956)

A TU $\Leftrightarrow \forall b \in \mathbb{Z}^m, Ax \leq b$ is *box-TDI*.

\rightarrow incidence matrix of a network is TU \Rightarrow MaxFlow-MinCut.

Equimodular matrix:

- A has full row rank r ,
- All the $r \times r$ nonzero subdeterminants of A have the same absolute value.

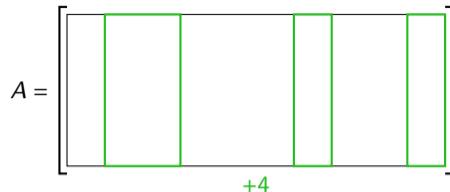

Box-TDIness from the structure of the matrix A

Let $A \in \mathbb{Z}^{r \times n}$ be a matrix.

Totally unimodular (TU) matrix:

- All the nonzero subdeterminants of A are ± 1 .

Theorem (Hoffman, Kruskal, 1956)

A TU $\Leftrightarrow \forall b \in \mathbb{Z}^m, Ax \leq b$ is box-TDI.

\rightarrow incidence matrix of a network is TU \Rightarrow MaxFlow-MinCut.

Equimodular matrix:

- A has full row rank r ,
- All the $r \times r$ nonzero subdeterminants of A have the same absolute value.

Totally equimodular (TE) matrix:

- All the full row rank submatrices of A are equimodular.

$A =$



Box-TDIness from the structure of the matrix A

Let $A \in \mathbb{Z}^{r \times n}$ be a matrix.

Totally unimodular (TU) matrix:

- All the nonzero subdeterminants of A are ± 1 .

Theorem (Hoffman, Kruskal, 1956)

A TU $\Leftrightarrow \forall b \in \mathbb{Z}^m, Ax \leq b$ is box-TDI.

\rightarrow incidence matrix of a network is TU \Rightarrow MaxFlow-MinCut.

Equimodular matrix:

- A has full row rank r ,
- All the $r \times r$ nonzero subdeterminants of A have the same absolute value.

Totally equimodular (TE) matrix:

- All the full row rank submatrices of A are equimodular.

$$A = \left[\begin{array}{c} \text{Full row rank} \Rightarrow \text{Equimodular} \end{array} \right]$$

Box-TDIness from the structure of the matrix A

Let $A \in \mathbb{Z}^{r \times n}$ be a matrix.

Totally unimodular (TU) matrix:

- All the nonzero subdeterminants of A are ± 1 .

Theorem (Hoffman, Kruskal, 1956)

A TU $\Leftrightarrow \forall b \in \mathbb{Z}^m, Ax \leq b$ is box-TDI.

\rightarrow incidence matrix of a network is TU \Rightarrow MaxFlow-MinCut.

Equimodular matrix:

- A has full row rank r ,
- All the $r \times r$ nonzero subdeterminants of A have the same absolute value.

Totally equimodular (TE) matrix:

- All the full row rank submatrices of A are equimodular.

\rightarrow we can suppose A is $0, \pm 1$.

$A =$



Box-TDIness from the structure of the matrix A

Let $A \in \mathbb{Z}^{r \times n}$ be a matrix.

Totally unimodular (TU) matrix:

- All the nonzero subdeterminants of A are ± 1 .

Theorem (Hoffman, Kruskal, 1956)

A TU $\Leftrightarrow \forall b \in \mathbb{Z}^m, Ax \leq b$ is box-TDI.

\rightarrow incidence matrix of a network is TU \Rightarrow MaxFlow-MinCut.

Equimodular matrix:

- A has full row rank r ,
- All the $r \times r$ nonzero subdeterminants of A have the same absolute value.

Totally equimodular (TE) matrix:

- All the full row rank submatrices of A are equimodular.

\rightarrow we can suppose A is $0, \pm 1$.

$A =$



Theorem (CGR, 2021)

A TE $\Leftrightarrow \forall b \in \mathbb{Q}^m, \{x \mid Ax \leq b\}$ is a box-TDI polyhedron.

Box-TDIness from the structure of the matrix A

Let $A \in \mathbb{Z}^{r \times n}$ be a matrix.

Totally unimodular (TU) matrix:

- All the nonzero subdeterminants of A are ± 1 .

Theorem (Hoffman, Kruskal, 1956)

A TU $\Leftrightarrow \forall b \in \mathbb{Z}^m, Ax \leq b$ is *box-TDI*.

\rightarrow incidence matrix of a network is TU \Rightarrow MaxFlow-MinCut.

Equimodular matrix:

- A has full row rank r ,
- All the $r \times r$ nonzero subdeterminants of A have the same absolute value.

Totally equimodular (TE) matrix:

- All the full row rank submatrices of A are equimodular.

\rightarrow we can suppose A is 0, ± 1 .

$A =$

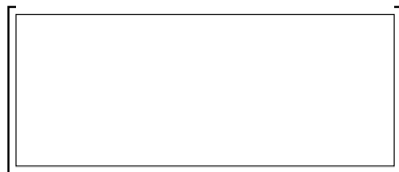

Theorem (CGR, 2021)

A TE $\Leftrightarrow \forall b \in \mathbb{Q}^m, \{x \mid Ax \leq b\}$ is a *box-TDI polyhedron*.

rows of a matrix \simeq set of vectors.

Question

Is there a decomposition theorem for

TE matrices \simeq te-sets ?

\rightarrow case of **linearly independent** te-sets.

Building blocks of linearly independent te-sets with r rows

Type of te-sets

det

examples

Building blocks of linearly independent te-sets with r rows

Type of te-sets

det

examples

1

tu-set

totally unimodular

Building blocks of linearly independent te-sets with r rows

Type of te-sets	det	examples
tu-set totally unimodular	1	$\begin{bmatrix} 1 & 0 & 1 & 0 \\ 0 & 1 & 1 & 0 \\ 0 & 0 & -1 & 0 \end{bmatrix}$

Building blocks of linearly independent te-sets with r rows

Type of te-sets	det	examples
tu-set totally unimodular	1	$\begin{bmatrix} 1 & 0 & 1 & 0 \\ 0 & 1 & 1 & 0 \\ 0 & 0 & -1 & 0 \end{bmatrix}$

te-lace

not a tu-set, every
proper subset is a
tu-set

Building blocks of linearly independent te-sets with r rows

Type of te-sets	det	examples
tu-set totally unimodular	1	$\begin{bmatrix} 1 & 0 & 1 & 0 \\ 0 & 1 & 1 & 0 \\ 0 & 0 & -1 & 0 \end{bmatrix}$

te-lace
not a tu-set, every
proper subset is a
tu-set

Building blocks of linearly independent te-sets with r rows

Type of te-sets	det	examples
tu-set totally unimodular	1	$\begin{bmatrix} 1 & 0 & 1 & 0 \\ 0 & 1 & 1 & 0 \\ 0 & 0 & -1 & 0 \end{bmatrix}$
te-lace not a tu-set, every proper subset is a tu-set	2	$\begin{bmatrix} 1 & 1 & 1 & 0 \\ 1 & -1 & 1 & 0 \end{bmatrix}$

Building blocks of linearly independent te-sets with r rows

Type of te-sets	det	examples
tu-set totally unimodular	1	$\begin{bmatrix} 1 & 0 & 1 & 0 \\ 0 & 1 & 1 & 0 \\ 0 & 0 & -1 & 0 \end{bmatrix}$
te-lace not a tu-set, every proper subset is a tu-set	2	$\begin{bmatrix} 1 & 1 & 1 & 0 \\ 1 & -1 & 1 & 0 \\ 1 & 1 & 0 & -1 \\ 1 & 0 & 1 & -1 \\ 0 & 1 & 1 & 0 \end{bmatrix}$

Building blocks of linearly independent te-sets with r rows

Type of te-sets	det	examples
tu-set totally unimodular	1	$\begin{bmatrix} 1 & 0 & 1 & 0 \\ 0 & 1 & 1 & 0 \\ 0 & 0 & -1 & 0 \end{bmatrix}$
te-lace not a tu-set, every proper subset is a tu-set	2	$\begin{bmatrix} 1 & 1 & 1 & 0 \\ 1 & -1 & 1 & 0 \\ 1 & 1 & 0 & -1 \\ 1 & 0 & 1 & -1 \\ 0 & 1 & 1 & 0 \end{bmatrix}$
te-interlace not a tu-set, every pair forms a te-lace		

Building blocks of linearly independent te-sets with r rows

Type of te-sets	det	examples
tu-set totally unimodular	1	$\begin{bmatrix} 1 & 0 & 1 & 0 \\ 0 & 1 & 1 & 0 \\ 0 & 0 & -1 & 0 \end{bmatrix}$
te-lace not a tu-set, every proper subset is a tu-set	2	$\begin{bmatrix} 1 & 1 & 1 & 0 \\ 1 & -1 & 1 & 0 \\ 1 & 1 & 0 & -1 \\ 1 & 0 & 1 & -1 \\ 0 & 1 & 1 & 0 \end{bmatrix}$
te-interlace not a tu-set, every pair forms a te-lace	thin: 2^{r-1}	

Building blocks of linearly independent te-sets with r rows

Type of te-sets	det	examples
tu-set totally unimodular	1	$\begin{bmatrix} 1 & 0 & 1 & 0 \\ 0 & 1 & 1 & 0 \\ 0 & 0 & -1 & 0 \end{bmatrix}$
te-lace not a tu-set, every proper subset is a tu-set	2	$\begin{bmatrix} 1 & 1 & 1 & 0 \\ 1 & -1 & 1 & 0 \\ 1 & 1 & 0 & -1 \\ 1 & 0 & 1 & -1 \\ 0 & 1 & 1 & 0 \end{bmatrix}$
te-interlace not a tu-set, every pair forms a te-lace	thin: 2^{r-1}	$\begin{bmatrix} 1 & 1 & 0 & 1 \\ 1 & -1 & 0 & 1 \\ 1 & 1 & 0 & -1 \end{bmatrix}$

Building blocks of linearly independent te-sets with r rows

Type of te-sets	det	examples
tu-set totally unimodular	1	$\begin{bmatrix} 1 & 0 & 1 & 0 \\ 0 & 1 & 1 & 0 \\ 0 & 0 & -1 & 0 \end{bmatrix}$
te-lace not a tu-set, every proper subset is a tu-set	2	$\begin{bmatrix} 1 & 1 & 1 & 0 \\ 1 & -1 & 1 & 0 \\ 1 & 1 & 0 & -1 \\ 1 & 0 & 1 & -1 \\ 0 & 1 & 1 & 0 \end{bmatrix}$
te-interlace not a tu-set, every pair forms a te-lace	thin: 2^{r-1}	$\begin{bmatrix} 1 & 1 & 0 & 1 \\ 1 & -1 & 0 & 1 \\ 1 & 1 & 0 & -1 \end{bmatrix}$
	thick: 2^r	

Building blocks of linearly independent te-sets with r rows

Type of te-sets	det	examples
tu-set totally unimodular	1	$\begin{bmatrix} 1 & 0 & 1 & 0 \\ 0 & 1 & 1 & 0 \\ 0 & 0 & -1 & 0 \end{bmatrix}$
te-lace not a tu-set, every proper subset is a tu-set	2	$\begin{bmatrix} 1 & 1 & 1 & 0 \\ 1 & -1 & 1 & 0 \\ 1 & 1 & 0 & -1 \\ 1 & 0 & 1 & -1 \\ 0 & 1 & 1 & 0 \end{bmatrix}$
te-interlace not a tu-set, every pair forms a te-lace	thin: 2^{r-1}	$\begin{bmatrix} 1 & 1 & 0 & 1 \\ 1 & -1 & 0 & 1 \\ 1 & 1 & 0 & -1 \end{bmatrix}$
	thick: 2^r	$\begin{bmatrix} 1 & 1 & 1 & 1 \\ 1 & 1 & -1 & -1 \\ 1 & -1 & -1 & 1 \\ 1 & -1 & 1 & -1 \end{bmatrix}$

Building blocks of linearly independent te-sets with r rows

Type of te-sets	det	examples
tu-set totally unimodular	1	$\begin{bmatrix} 1 & 0 & 1 & 0 \\ 0 & 1 & 1 & 0 \\ 0 & 0 & -1 & 0 \end{bmatrix}$
te-lace not a tu-set, every proper subset is a tu-set	2	$\begin{bmatrix} 1 & 1 & 1 & 0 \\ 1 & -1 & 1 & 0 \\ 1 & 1 & 0 & -1 \\ 1 & 0 & 1 & -1 \\ 0 & 1 & 1 & 0 \end{bmatrix}$
te-interlace not a tu-set, every pair forms a te-lace	thin: 2^{r-1}	$\begin{bmatrix} 1 & 1 & 0 & 1 \\ 1 & -1 & 0 & 1 \\ 1 & 1 & 0 & -1 \end{bmatrix}$
	thick: 2^r	$\begin{bmatrix} 1 & 1 & 1 & 1 \\ 1 & 1 & -1 & -1 \\ 1 & -1 & -1 & 1 \\ 1 & -1 & 1 & -1 \end{bmatrix}$

Proposition (Chervet, Grappe, V., 2026)

The columns of a te-lace or of a thick te-interlace of size r are $\mathbf{0}$ or \pm copies of any of its nonsingular $r \times r$ submatrix.

Building blocks of linearly independent te-sets with r rows

Type of te-sets	det	examples
tu-set totally unimodular	1	$\begin{bmatrix} 1 & 0 & 1 & 0 \\ 0 & 1 & 1 & 0 \\ 0 & 0 & -1 & 0 \end{bmatrix}$
te-lace not a tu-set, every proper subset is a tu-set	2	$\begin{bmatrix} 1 & 1 & 1 & 0 \\ 1 & -1 & 1 & 0 \\ 1 & 1 & 0 & -1 \\ 1 & 0 & 1 & -1 \\ 0 & 1 & 1 & 0 \end{bmatrix}$
te-interlace not a tu-set, every pair forms a te-lace	thin: 2^{r-1}	$\begin{bmatrix} 1 & 1 & 0 & 1 \\ 1 & -1 & 0 & 1 \\ 1 & 1 & 0 & -1 \end{bmatrix}$
	thick: 2^r	$\begin{bmatrix} 1 & 1 & 1 & 1 \\ 1 & 1 & -1 & -1 \\ 1 & -1 & -1 & 1 \\ 1 & -1 & 1 & -1 \end{bmatrix}$

Proposition (Chervet, Grappe, V., 2026)

The columns of a te-lace or of a thick te-interlace of size r are $\mathbf{0}$ or \pm copies of any of its nonsingular $r \times r$ submatrix.

Proposition (Chervet, Grappe, V., 2026)

*Thick te-interlaces have **even** size at least 4.*

Building blocks of linearly independent te-sets with r rows

Type of te-sets	det	examples
tu-set totally unimodular	1	$\begin{bmatrix} 1 & 0 & 1 & 0 \\ 0 & 1 & 1 & 0 \\ 0 & 0 & -1 & 0 \end{bmatrix}$
te-lace not a tu-set, every proper subset is a tu-set	2	$\begin{bmatrix} 1 & 1 & 1 & 0 \\ 1 & -1 & 1 & 0 \\ 1 & 1 & 0 & -1 \\ 1 & 0 & 1 & -1 \\ 0 & 1 & 1 & 0 \end{bmatrix}$
te-interlace not a tu-set, every pair forms a te-lace	thin: 2^{r-1}	$\begin{bmatrix} 1 & 1 & 0 & 1 \\ 1 & -1 & 0 & 1 \\ 1 & 1 & 0 & -1 \end{bmatrix}$
	thick: 2^r	$\begin{bmatrix} 1 & 1 & 1 & 1 \\ 1 & 1 & -1 & -1 \\ 1 & -1 & -1 & 1 \\ 1 & -1 & 1 & -1 \end{bmatrix}$

Proposition (Chervet, Grappe, V., 2026)

The columns of a te-lace or of a thick te-interlace of size r are $\mathbf{0}$ or \pm copies of any of its nonsingular $r \times r$ submatrix.

Proposition (Chervet, Grappe, V., 2026)

*Thick te-interlaces have **even** size at least 4.*

Theorem (Chervet, Grappe, V., 2026)

Let A be a set of r linearly independent $0, \pm 1$ vectors. Then, A is a te-set if and only if it can be partitioned as follows.

$$A = \underbrace{U}_{\text{tu-set}} \sqcup \underbrace{L_1 \sqcup \dots \sqcup L_k}_{\text{te-laces}} \sqcup \underbrace{S_1 \sqcup \dots \sqcup S_\ell}_{\text{thin te-interlaces}} \sqcup \underbrace{T_1 \sqcup \dots \sqcup T_m}_{\text{thick te-interlaces}}$$

*where $U, L_1, \dots, L_k, S_1, \dots, S_\ell, \dots, T_1, \dots, T_m$ are **mutually-tu**.*

Building blocks of linearly independent te-sets with r rows

Type of te-sets	det	examples
tu-set totally unimodular	1	$\begin{bmatrix} 1 & 0 & 1 & 0 \\ 0 & 1 & 1 & 0 \\ 0 & 0 & -1 & 0 \end{bmatrix}$
te-lace not a tu-set, every proper subset is a tu-set	2	$\begin{bmatrix} 1 & 1 & 1 & 0 \\ 1 & -1 & 1 & 0 \\ 1 & 1 & 0 & -1 \\ 1 & 0 & 1 & -1 \\ 0 & 1 & 1 & 0 \end{bmatrix}$
te-interlace not a tu-set, every pair forms a te-lace	thin: 2^{r-1}	$\begin{bmatrix} 1 & 1 & 0 & 1 \\ 1 & -1 & 0 & 1 \\ 1 & 1 & 0 & -1 \end{bmatrix}$
	thick: 2^r	$\begin{bmatrix} 1 & 1 & 1 & 1 \\ 1 & 1 & -1 & -1 \\ 1 & -1 & -1 & 1 \\ 1 & -1 & 1 & -1 \end{bmatrix}$

Proposition (Chervet, Grappe, V., 2026)

The columns of a te-lace or of a thick te-interlace of size r are $\mathbf{0}$ or \pm copies of any of its nonsingular $r \times r$ submatrix.

Proposition (Chervet, Grappe, V., 2026)

Thick te-interlaces have *even* size at least 4.

Theorem (Chervet, Grappe, V., 2026)

Let A be a set of r linearly independent $0, \pm 1$ vectors. Then, A is a te-set if and only if it can be partitioned as follows.

$$A = \underbrace{U}_{\text{tu-set}} \sqcup \underbrace{L_1 \sqcup \dots \sqcup L_k}_{\text{te-laces}} \sqcup \underbrace{S_1 \sqcup \dots \sqcup S_\ell}_{\text{thin te-interlaces}} \sqcup \underbrace{T_1 \sqcup \dots \sqcup T_m}_{\text{thick te-interlaces}}$$

where $U, L_1, \dots, L_k, S_1, \dots, S_\ell, \dots, T_1, \dots, T_m$ are *mutually-tu*.

→ Cones and their Hilbert bases?

Section 3

Totally equimodular cones: triangulation

Hilbert basis of te-cones and integer decomposition properties

te-cone: cone generated by a te-set.

Theorem (Chervet, Grappe, V., 2026)

The Hilbert basis of the cone generated by a te-brick A is:

- *tu-set:* A
- *te-lace:* $A \cup \{h = \frac{1}{2} \sum_i a_i\}$
- *thick te-interlace:* $A \cup \{\frac{1}{2}(a_i + a_j)\}_{i \neq j}$
- *thin te-interlace:*

$$A \cup \{\frac{1}{2}(a_i + a_j)\}_{i \neq j} \cup \begin{cases} \{\frac{1}{4} \sum_i a_i\}, \text{ or} \\ \{\frac{3}{4}a_i + \frac{1}{4} \sum_{j \neq i} a_j\}_i. \end{cases}$$

Theorem (Carathéodory for cones)

We need at most $n = \dim C$ generators of a rational cone C to $\mathbb{Q}_{>0}$ -generate any rational $c \in C$.

Hilbert basis of te-cones and integer decomposition properties

te-cone: cone generated by a te-set.

Theorem (Chervet, Grappe, V., 2026)

The Hilbert basis of the cone generated by a te-brick A is:

- *tu-set:* A
- *te-lace:* $A \cup \{h = \frac{1}{2} \sum_i a_i\}$
- *thick te-interlace:* $A \cup \{\frac{1}{2}(a_i + a_j)\}_{i \neq j}$
- *thin te-interlace:*

$$A \cup \{\frac{1}{2}(a_i + a_j)\}_{i \neq j} \cup \begin{cases} \{\frac{1}{4} \sum_i a_i\}, \text{ or} \\ \{\frac{3}{4}a_i + \frac{1}{4} \sum_{j \neq i} a_j\}_{i.} \end{cases}$$

Theorem (Carathéodory for cones)

We need at most $n = \dim C$ generators of a rational cone C to $\mathbb{Q}_{>0}$ -generate any rational $c \in C$.

Question

How many Hilbert basis elements are needed to $\mathbb{Z}_{>0}$ -generate an **integer** vector c ?

Hilbert basis of te-cones and integer decomposition properties

te-cone: cone generated by a te-set.

Theorem (Chervet, Grappe, V., 2026)

The Hilbert basis of the cone generated by a te-brick A is:

- *tu-set:* A
- *te-lace:* $A \cup \{h = \frac{1}{2} \sum_i a_i\}$
- *thick te-interlace:* $A \cup \{\frac{1}{2}(a_i + a_j)\}_{i \neq j}$
- *thin te-interlace:*

$$A \cup \{\frac{1}{2}(a_i + a_j)\}_{i \neq j} \cup \begin{cases} \{\frac{1}{4} \sum_i a_i\}, \text{ or} \\ \{\frac{3}{4}a_i + \frac{1}{4} \sum_{j \neq i} a_j\}_i. \end{cases}$$

Theorem (Carathéodory for cones)

We need at most $n = \dim C$ generators of a rational cone C to $\mathbb{Q}_{>0}$ -generate any rational $c \in C$.

Question

How many Hilbert basis elements are needed to $\mathbb{Z}_{>0}$ -generate an **integer** vector c ?

- **Cook, Fonlupt, Schrijver, 1986:** $2n - 1$ suffice

Hilbert basis of te-cones and integer decomposition properties

te-cone: cone generated by a te-set.

Theorem (Chervet, Grappe, V., 2026)

The Hilbert basis of the cone generated by a te-brick A is:

- *tu-set:* A
- *te-lace:* $A \cup \{h = \frac{1}{2} \sum_i a_i\}$
- *thick te-interlace:* $A \cup \{\frac{1}{2}(a_i + a_j)\}_{i \neq j}$
- *thin te-interlace:*

$$A \cup \{\frac{1}{2}(a_i + a_j)\}_{i \neq j} \cup \begin{cases} \{\frac{1}{4} \sum_i a_i\}, \text{ or} \\ \{\frac{3}{4}a_i + \frac{1}{4} \sum_{j \neq i} a_j\}_i. \end{cases}$$

Theorem (Carathéodory for cones)

We need at most $n = \dim C$ generators of a rational cone C to $\mathbb{Q}_{>0}$ -generate any rational $c \in C$.

Question

How many Hilbert basis elements are needed to $\mathbb{Z}_{>0}$ -generate an **integer** vector c ?

- **Cook, Fonlupt, Schrijver, 1986:** $2n - 1$ suffice
- **Sebő, 1990:** $2n - 2$ suffice

Hilbert basis of te-cones and integer decomposition properties

te-cone: cone generated by a te-set.

Theorem (Chervet, Grappe, V., 2026)

The Hilbert basis of the cone generated by a te-brick A is:

- *tu-set:* A
- *te-lace:* $A \cup \{h = \frac{1}{2} \sum_i a_i\}$
- *thick te-interlace:* $A \cup \{\frac{1}{2}(a_i + a_j)\}_{i \neq j}$
- *thin te-interlace:*

$$A \cup \{\frac{1}{2}(a_i + a_j)\}_{i \neq j} \cup \begin{cases} \{\frac{1}{4} \sum_i a_i\}, \text{ or} \\ \{\frac{3}{4}a_i + \frac{1}{4} \sum_{j \neq i} a_j\}_i. \end{cases}$$

Theorem (Carathéodory for cones)

We need at most $n = \dim C$ generators of a rational cone C to $\mathbb{Q}_{>0}$ -generate any rational $c \in C$.

Question

How many Hilbert basis elements are needed to $\mathbb{Z}_{>0}$ -generate an **integer** vector c ?

- **Cook, Fonlupt, Schrijver, 1986:** $2n - 1$ suffice
- **Sebő, 1990:** $2n - 2$ suffice

If n suffice, then C satisfies the **Integer Carathéodory property (ICP)**.

Hilbert basis of te-cones and integer decomposition properties

te-cone: cone generated by a te-set.

Theorem (Chervet, Grappe, V., 2026)

The Hilbert basis of the cone generated by a te-brick A is:

- *tu-set:* A
- *te-lace:* $A \cup \{h = \frac{1}{2} \sum_i a_i\}$
- *thick te-interlace:* $A \cup \{\frac{1}{2}(a_i + a_j)\}_{i \neq j}$
- *thin te-interlace:*

$$A \cup \{\frac{1}{2}(a_i + a_j)\}_{i \neq j} \cup \begin{cases} \{\frac{1}{4} \sum_i a_i\}, \text{ or} \\ \{\frac{3}{4}a_i + \frac{1}{4} \sum_{j \neq i} a_j\}_i. \end{cases}$$

Theorem (Carathéodory for cones)

We need at most $n = \dim C$ generators of a rational cone C to $\mathbb{Q}_{>0}$ -generate any rational $c \in C$.

Question

How many Hilbert basis elements are needed to $\mathbb{Z}_{>0}$ -generate an **integer** vector c ?

- **Cook, Fonlupt, Schrijver, 1986:** $2n - 1$ suffice
- **Sebő, 1990:** $2n - 2$ suffice

If n suffice, then C satisfies the **Integer Carathéodory property (ICP)**.

→ ICP guarantees the existence of a **sparse solution** in the dual optimization problem (TDI).

Hilbert basis of te-cones and integer decomposition properties

te-cone: cone generated by a te-set.

Theorem (Chervet, Grappe, V., 2026)

The Hilbert basis of the cone generated by a te-brick A is:

- *tu-set:* A
- *te-lace:* $A \cup \{h = \frac{1}{2} \sum_i a_i\}$
- *thick te-interlace:* $A \cup \{\frac{1}{2}(a_i + a_j)\}_{i \neq j}$
- *thin te-interlace:*

$$A \cup \{\frac{1}{2}(a_i + a_j)\}_{i \neq j} \cup \begin{cases} \{\frac{1}{4} \sum_i a_i\}, \text{ or} \\ \{\frac{3}{4}a_i + \frac{1}{4} \sum_{j \neq i} a_j\}_{i.} \end{cases}$$

Theorem (Carathéodory for cones)

We need at most $n = \dim C$ generators of a rational cone C to $\mathbb{Q}_{>0}$ -generate any rational $c \in C$.

Question

How many Hilbert basis elements are needed to $\mathbb{Z}_{>0}$ -generate an **integer** vector c ?

- **Cook, Fonlupt, Schrijver, 1986:** $2n - 1$ suffice
- **Sebő, 1990:** $2n - 2$ suffice

If n suffice, then C satisfies the **Integer Carathéodory property (ICP)**.

→ ICP guarantees the existence of a **sparse solution** in the dual optimization problem (TDI).

Question

Do totally equimodular cones satisfy the ICP?

unimodular cone: spanned by part of a basis of \mathbb{Z}^n

→ direct integer decomposition for $x \in C \cap \mathbb{Z}^n$.

unimodular cone: spanned by part of a basis of \mathbb{Z}^n

→ direct integer decomposition for $x \in C \cap \mathbb{Z}^n$.

✓ tu-sets

unimodular cone: spanned by part of a basis of \mathbb{Z}^n

→ direct integer decomposition for $x \in C \cap \mathbb{Z}^n$.

✓ tu-sets

Definition (Unimodular Hilbert triangulation)

A collection of cones Σ is a UHT of C if:

unimodular cone: spanned by part of a basis of \mathbb{Z}^n
→ direct integer decomposition for $x \in C \cap \mathbb{Z}^n$.

✓ tu-sets

Definition (Unimodular Hilbert triangulation)

A collection of cones Σ is a UHT of C if:

- Every $C \in \Sigma$ are generated by **Hilbert basis** elements of C ,

unimodular cone: spanned by part of a basis of \mathbb{Z}^n
→ direct integer decomposition for $x \in C \cap \mathbb{Z}^n$.

✓ tu-sets

Definition (Unimodular Hilbert triangulation)

A collection of cones Σ is a UHT of C if:

- Every $C \in \Sigma$ are generated by **Hilbert basis** elements of C ,
- $\forall C_1, C_2 \in \Sigma, C_1 \cap C_2$ is a **face** of both,

unimodular cone: spanned by part of a basis of \mathbb{Z}^n
→ direct integer decomposition for $x \in C \cap \mathbb{Z}^n$.

✓ tu-sets

Definition (Unimodular Hilbert triangulation)

A collection of cones Σ is a UHT of C if:

- Every $C \in \Sigma$ are generated by **Hilbert basis** elements of C ,
- $\forall C_1, C_2 \in \Sigma, C_1 \cap C_2$ is a **face** of both,
- $C = \bigcup_{C' \in \Sigma} C'$.

unimodular cone: spanned by part of a basis of \mathbb{Z}^n
→ direct integer decomposition for $x \in C \cap \mathbb{Z}^n$.

✓ tu-sets

Definition (Unimodular Hilbert triangulation)

A collection of cones Σ is a UHT of C if:

- Every $C \in \Sigma$ are generated by **Hilbert basis** elements of C ,
- $\forall C_1, C_2 \in \Sigma, C_1 \cap C_2$ is a **face** of both,
- $C = \bigcup_{C' \in \Sigma} C'$.

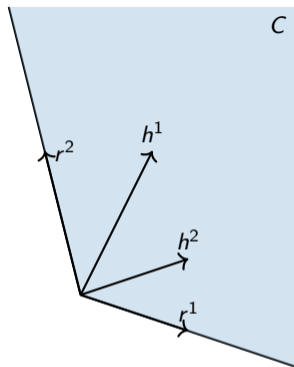

Unimodular Hilbert triangulation

$$C = \text{cone}\{r^1, \dots, r^s\}$$

unimodular cone: spanned by part of a basis of \mathbb{Z}^n
→ direct integer decomposition for $x \in C \cap \mathbb{Z}^n$.

✓ tu-sets

Definition (Unimodular Hilbert triangulation)

A collection of cones Σ is a UHT of C if:

- Every $C \in \Sigma$ are generated by **Hilbert basis** elements of C ,
- $\forall C_1, C_2 \in \Sigma, C_1 \cap C_2$ is a **face** of both,
- $C = \bigcup_{C' \in \Sigma} C'$.

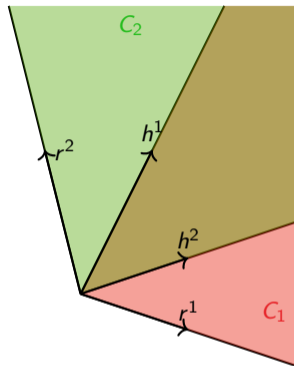

unimodular cone: spanned by part of a basis of \mathbb{Z}^n
→ direct integer decomposition for $x \in C \cap \mathbb{Z}^n$.

✓ tu-sets

Definition (Unimodular Hilbert triangulation)

A collection of cones Σ is a UHT of C if:

- Every $C \in \Sigma$ are generated by **Hilbert basis** elements of C ,
- $\forall C_1, C_2 \in \Sigma, C_1 \cap C_2$ is a **face** of both,
- $C = \bigcup_{C' \in \Sigma} C'$.

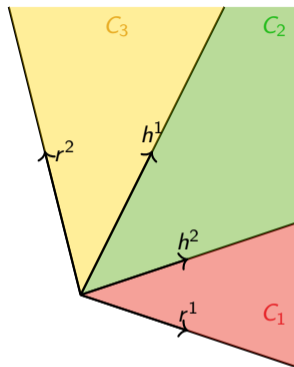

Unimodular Hilbert triangulation

$$C = \text{cone}\{r^1, \dots, r^s\}$$

unimodular cone: spanned by part of a basis of \mathbb{Z}^n
→ direct integer decomposition for $x \in C \cap \mathbb{Z}^n$.

✓ tu-sets

Definition (Unimodular Hilbert triangulation)

A collection of cones Σ is a UHT of C if:

- Every $C \in \Sigma$ are generated by **Hilbert basis** elements of C ,
- $\forall C_1, C_2 \in \Sigma, C_1 \cap C_2$ is a **face** of both,
- $C = \bigcup_{C' \in \Sigma} C'$.

Fact: UHT \Rightarrow ICP.

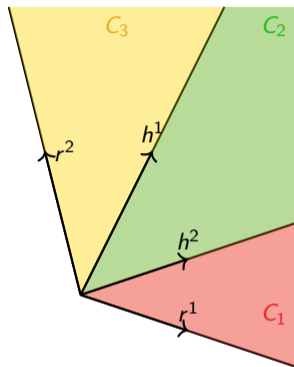

unimodular cone: spanned by part of a basis of \mathbb{Z}^n
→ direct integer decomposition for $x \in C \cap \mathbb{Z}^n$.

✓ tu-sets

Definition (Unimodular Hilbert triangulation)

A collection of cones Σ is a UHT of C if:

- Every $C \in \Sigma$ are generated by **Hilbert basis** elements of C ,
- $\forall C_1, C_2 \in \Sigma, C_1 \cap C_2$ is a **face** of both,
- $C = \bigcup_{C' \in \Sigma} C'$.

Fact: UHT \Rightarrow ICP.

If C simplicial, $h \in \text{relint } C$, the **stellar triangulation** of C at h is:

$$\mathcal{S}_h(C) = \{C_1, \dots, C_s\},$$

unimodular cone: spanned by part of a basis of \mathbb{Z}^n
→ direct integer decomposition for $x \in C \cap \mathbb{Z}^n$.

✓ tu-sets

Definition (Unimodular Hilbert triangulation)

A collection of cones Σ is a UHT of C if:

- Every $C \in \Sigma$ are generated by **Hilbert basis** elements of C ,
- $\forall C_1, C_2 \in \Sigma, C_1 \cap C_2$ is a **face** of both,
- $C = \bigcup_{C' \in \Sigma} C'$.

Fact: UHT \Rightarrow ICP.

If C simplicial, $h \in \text{relint } C$, the **stellar triangulation** of C at h is:

$$\mathcal{S}_h(C) = \{C_1, \dots, C_s\},$$

with

$$C_i = \text{cone}\{r^1, \dots, r^{i-1}, h, r^{i+1}, \dots, r^s\}.$$

unimodular cone: spanned by part of a basis of \mathbb{Z}^n
→ direct integer decomposition for $x \in C \cap \mathbb{Z}^n$.

✓ tu-sets

Definition (Unimodular Hilbert triangulation)

A collection of cones Σ is a UHT of C if:

- Every $C \in \Sigma$ are generated by **Hilbert basis** elements of C ,
- $\forall C_1, C_2 \in \Sigma, C_1 \cap C_2$ is a **face** of both,
- $C = \bigcup_{C' \in \Sigma} C'$.

Fact: UHT \Rightarrow ICP.

If C simplicial, $h \in \text{relint } C$, the **stellar triangulation** of C at h is:

$$\mathcal{S}_h(C) = \{C_1, \dots, C_s\},$$

with

$$C_i = \text{cone}\{r^1, \dots, r^{i-1}, h, r^{i+1}, \dots, r^s\}.$$

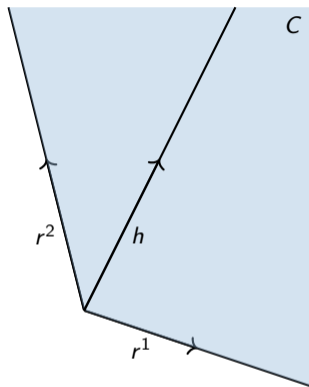

unimodular cone: spanned by part of a basis of \mathbb{Z}^n
→ direct integer decomposition for $x \in C \cap \mathbb{Z}^n$.

✓ tu-sets

Definition (Unimodular Hilbert triangulation)

A collection of cones Σ is a UHT of C if:

- Every $C \in \Sigma$ are generated by **Hilbert basis** elements of C ,
- $\forall C_1, C_2 \in \Sigma, C_1 \cap C_2$ is a **face** of both,
- $C = \bigcup_{C' \in \Sigma} C'$.

Fact: UHT \Rightarrow ICP.

If C simplicial, $h \in \text{relint } C$, the **stellar triangulation** of C at h is:

$$\mathcal{S}_h(C) = \{C_1, \dots, C_s\},$$

with

$$C_i = \text{cone}\{r^1, \dots, r^{i-1}, h, r^{i+1}, \dots, r^s\}.$$

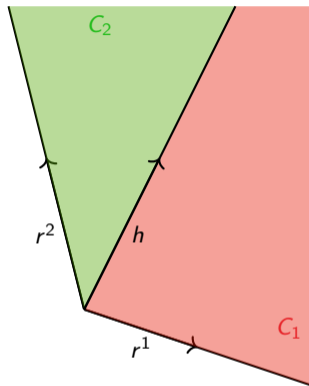

Unimodular Hilbert triangulation

$$C = \text{cone}\{r^1, \dots, r^s\}$$

unimodular cone: spanned by part of a basis of \mathbb{Z}^n
→ direct integer decomposition for $x \in C \cap \mathbb{Z}^n$.

✓ tu-sets

Definition (Unimodular Hilbert triangulation)

A collection of cones Σ is a UHT of C if:

- Every $C \in \Sigma$ are generated by **Hilbert basis** elements of C ,
- $\forall C_1, C_2 \in \Sigma, C_1 \cap C_2$ is a **face** of both,
- $C = \bigcup_{C' \in \Sigma} C'$.

Fact: UHT \Rightarrow ICP.

If C simplicial, $h \in \text{relint } C$, the **stellar triangulation** of C at h is:

$$\mathcal{S}_h(C) = \{C_1, \dots, C_s\},$$

with

$$C_i = \text{cone}\{r^1, \dots, r^{i-1}, h, r^{i+1}, \dots, r^s\}.$$

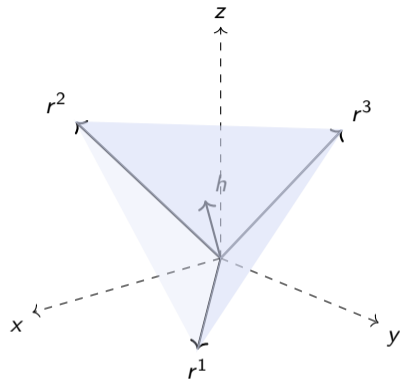

Unimodular Hilbert triangulation

$$C = \text{cone}\{r^1, \dots, r^s\}$$

unimodular cone: spanned by part of a basis of \mathbb{Z}^n
→ direct integer decomposition for $x \in C \cap \mathbb{Z}^n$.

✓ tu-sets

Definition (Unimodular Hilbert triangulation)

A collection of cones Σ is a UHT of C if:

- Every $C \in \Sigma$ are generated by **Hilbert basis** elements of C ,
- $\forall C_1, C_2 \in \Sigma, C_1 \cap C_2$ is a **face** of both,
- $C = \bigcup_{C' \in \Sigma} C'$.

Fact: UHT \Rightarrow ICP.

If C simplicial, $h \in \text{relint } C$, the **stellar triangulation** of C at h is:

$$\mathcal{S}_h(C) = \{C_1, \dots, C_s\},$$

with

$$C_i = \text{cone}\{r^1, \dots, r^{i-1}, h, r^{i+1}, \dots, r^s\}.$$

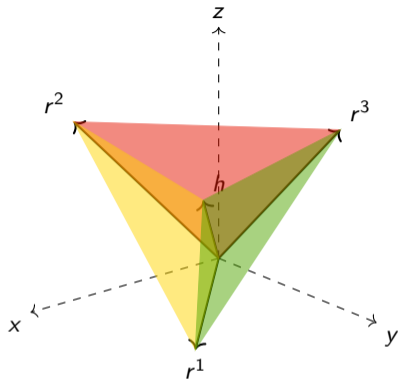

Unimodular Hilbert triangulation

$$C = \text{cone}\{r^1, \dots, r^s\}$$

unimodular cone: spanned by part of a basis of \mathbb{Z}^n
→ direct integer decomposition for $x \in C \cap \mathbb{Z}^n$.

✓ tu-sets

Definition (Unimodular Hilbert triangulation)

A collection of cones Σ is a UHT of C if:

- Every $C \in \Sigma$ are generated by **Hilbert basis** elements of C ,
- $\forall C_1, C_2 \in \Sigma, C_1 \cap C_2$ is a **face** of both,
- $C = \bigcup_{C' \in \Sigma} C'$.

Fact: UHT \Rightarrow ICP.

If C simplicial, $h \in \text{relint } C$, the **stellar triangulation** of C at h is:

$$\mathcal{S}_h(C) = \{C_1, \dots, C_s\},$$

with

$$C_i = \text{cone}\{r^1, \dots, r^{i-1}, h, r^{i+1}, \dots, r^s\}.$$

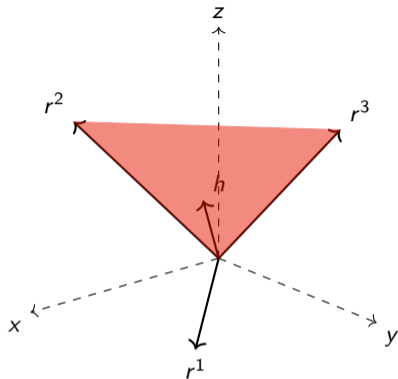

Unimodular Hilbert triangulation

$$C = \text{cone}\{r^1, \dots, r^s\}$$

unimodular cone: spanned by part of a basis of \mathbb{Z}^n
→ direct integer decomposition for $x \in C \cap \mathbb{Z}^n$.

✓ tu-sets

Definition (Unimodular Hilbert triangulation)

A collection of cones Σ is a UHT of C if:

- Every $C \in \Sigma$ are generated by **Hilbert basis** elements of C ,
- $\forall C_1, C_2 \in \Sigma, C_1 \cap C_2$ is a **face** of both,
- $C = \bigcup_{C' \in \Sigma} C'$.

Fact: UHT \Rightarrow ICP.

If C simplicial, $h \in \text{relint } C$, the **stellar triangulation** of C at h is:

$$\mathcal{S}_h(C) = \{C_1, \dots, C_s\},$$

with

$$C_i = \text{cone}\{r^1, \dots, r^{i-1}, h, r^{i+1}, \dots, r^s\}.$$

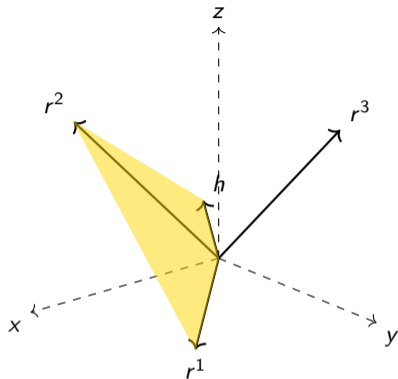

Unimodular Hilbert triangulation

$$C = \text{cone}\{r^1, \dots, r^s\}$$

unimodular cone: spanned by part of a basis of \mathbb{Z}^n
→ direct integer decomposition for $x \in C \cap \mathbb{Z}^n$.

✓ tu-sets

Definition (Unimodular Hilbert triangulation)

A collection of cones Σ is a UHT of C if:

- Every $C \in \Sigma$ are generated by **Hilbert basis** elements of C ,
- $\forall C_1, C_2 \in \Sigma, C_1 \cap C_2$ is a **face** of both,
- $C = \bigcup_{C' \in \Sigma} C'$.

Fact: UHT \Rightarrow ICP.

If C simplicial, $h \in \text{relint } C$, the **stellar triangulation** of C at h is:

$$\mathcal{S}_h(C) = \{C_1, \dots, C_s\},$$

with

$$C_i = \text{cone}\{r^1, \dots, r^{i-1}, h, r^{i+1}, \dots, r^s\}.$$

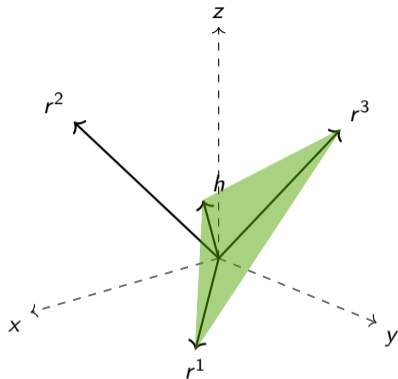

Proposition

Let C be a simplicial cone with determinant ± 2 whose all proper faces have determinant ± 1 . Then, $\mathcal{S}_h(C)$ is a RUHT, for h the half sum of its generators.

Unimodular Hilbert triangulation

$$C = \text{cone}\{r^1, \dots, r^s\}$$

unimodular cone: spanned by part of a basis of \mathbb{Z}^n
→ direct integer decomposition for $x \in C \cap \mathbb{Z}^n$.

✓ tu-sets

Definition (Unimodular Hilbert triangulation)

A collection of cones Σ is a UHT of C if:

- Every $C \in \Sigma$ are generated by **Hilbert basis** elements of C ,
- $\forall C_1, C_2 \in \Sigma, C_1 \cap C_2$ is a **face** of both,
- $C = \bigcup_{C' \in \Sigma} C'$.

Fact: UHT \Rightarrow ICP.

If C simplicial, $h \in \text{relint } C$, the **stellar triangulation** of C at h is:

$$\mathcal{S}_h(C) = \{C_1, \dots, C_s\},$$

with

$$C_i = \text{cone}\{r^1, \dots, r^{i-1}, h, r^{i+1}, \dots, r^s\}.$$

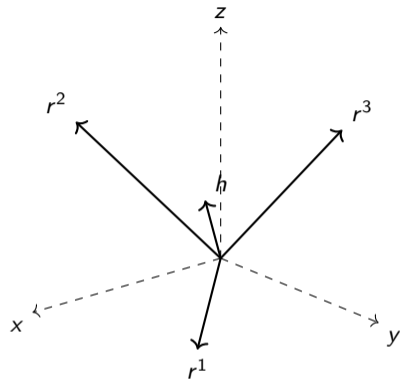

Proposition

Let C be a simplicial cone with determinant ± 2 whose all proper faces have determinant ± 1 . Then, $\mathcal{S}_h(C)$ is a RUHT, for h the half sum of its generators.

✓ te-laces

Triangulation of thin te-interlaces

We embed \hat{K}_n , the **complete graph** on n vertices with loops ii , as a convex n -gon in \mathbb{R}^2 :

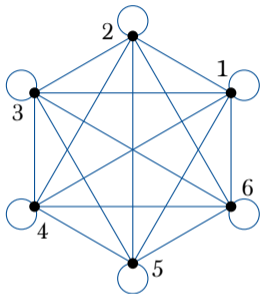

Triangulation of thin te-interlaces

We embed \hat{K}_n , the **complete graph** on n vertices with loops ii , as a convex n -gon in \mathbb{R}^2 :

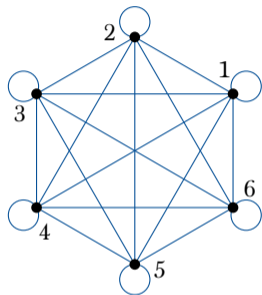

- vertices: $1, \dots, n \in \mathbb{R}^2$,

Triangulation of thin te-interlaces

We embed \mathring{K}_n , the **complete graph** on n vertices with loops ii , as a convex n -gon in \mathbb{R}^2 :

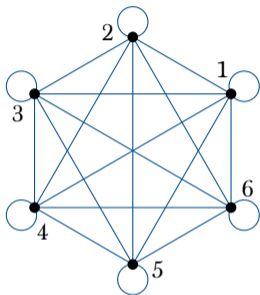

- vertices: $1, \dots, n \in \mathbb{R}^2$,
- edges: line segments $[i, j]$, for $i \neq j$, and circle containing $i = j$ for loops.

Triangulation of thin te-interlaces

We embed \mathring{K}_n , the **complete graph** on n vertices with loops ii , as a convex n -gon in \mathbb{R}^2 :

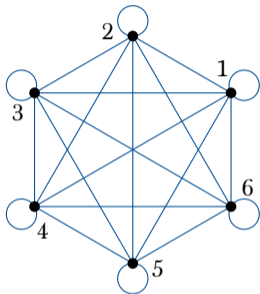

- vertices: $1, \dots, n \in \mathbb{R}^2$,
- edges: line segments $[i, j]$, for $i \neq j$, and circle containing $i = j$ for loops.

Two distinct edges **intersect** if the associated segments or circles meet in \mathbb{R}^2 .

Triangulation of thin te-interlaces

We embed \mathring{K}_n , the **complete graph** on n vertices with loops ii , as a convex n -gon in \mathbb{R}^2 :

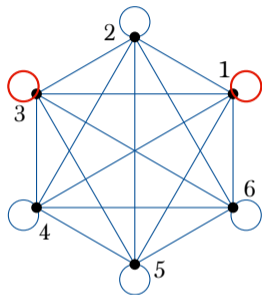

- vertices: $1, \dots, n \in \mathbb{R}^2$,
- edges: line segments $[i, j]$, for $i \neq j$, and circle containing $i = j$ for loops.

Two distinct edges **intersect** if the associated segments or circles meet in \mathbb{R}^2 .

Triangulation of thin te-interlaces

We embed \mathring{K}_n , the **complete graph** on n vertices with loops ii , as a convex n -gon in \mathbb{R}^2 :

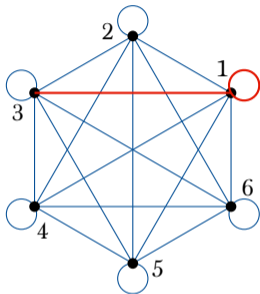

- vertices: $1, \dots, n \in \mathbb{R}^2$,
- edges: line segments $[i, j]$, for $i \neq j$, and circle containing $i = j$ for loops.

Two distinct edges **intersect** if the associated segments or circles meet in \mathbb{R}^2 .

Triangulation of thin te-interlaces

We embed \mathring{K}_n , the **complete graph** on n vertices with loops ii , as a convex n -gon in \mathbb{R}^2 :

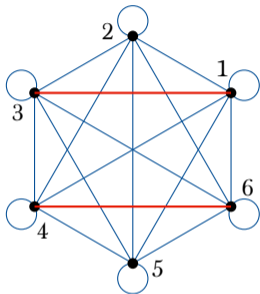

- vertices: $1, \dots, n \in \mathbb{R}^2$,
- edges: line segments $[i, j]$, for $i \neq j$, and circle containing $i = j$ for loops.

Two distinct edges **intersect** if the associated segments or circles meet in \mathbb{R}^2 .

Triangulation of thin te-interlaces

We embed \mathring{K}_n , the **complete graph** on n vertices with loops ii , as a convex n -gon in \mathbb{R}^2 :

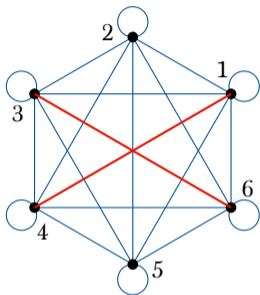

- vertices: $1, \dots, n \in \mathbb{R}^2$,
- edges: line segments $[i, j]$, for $i \neq j$, and circle containing $i = j$ for loops.

Two distinct edges **intersect** if the associated segments or circles meet in \mathbb{R}^2 .

Triangulation of thin te-interlaces

We embed \mathring{K}_n , the **complete graph** on n vertices with loops ii , as a convex n -gon in \mathbb{R}^2 :

Stellar cycle: subgraph S of K_n such that:

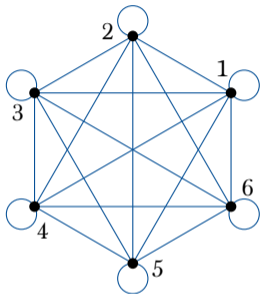

- vertices: $1, \dots, n \in \mathbb{R}^2$,
- edges: line segments $[i, j]$, for $i \neq j$, and circle containing $i = j$ for loops.

Two distinct edges **intersect** if the associated segments or circles meet in \mathbb{R}^2 .

Triangulation of thin te-interlaces

We embed \mathring{K}_n , the **complete graph** on n vertices with loops ii , as a convex n -gon in \mathbb{R}^2 :

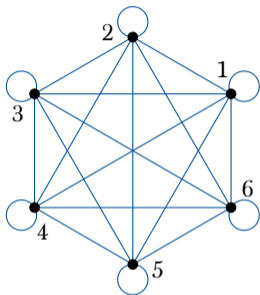

- vertices: $1, \dots, n \in \mathbb{R}^2$,
- edges: line segments $[i, j]$, for $i \neq j$, and circle containing $i = j$ for loops.

Two distinct edges **intersect** if the associated segments or circles meet in \mathbb{R}^2 .

Stellar cycle: subgraph S of K_n such that:

- S covers all the vertices of K_n

Triangulation of thin te-interlaces

We embed \mathring{K}_n , the **complete graph** on n vertices with loops ii , as a convex n -gon in \mathbb{R}^2 :

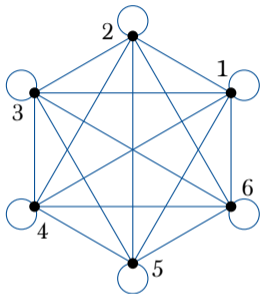

- vertices: $1, \dots, n \in \mathbb{R}^2$,
- edges: line segments $[i, j]$, for $i \neq j$, and circle containing $i = j$ for loops.

Two distinct edges **intersect** if the associated segments or circles meet in \mathbb{R}^2 .

Stellar cycle: subgraph S of K_n such that:

- S covers all the vertices of K_n
- S has n edges

Triangulation of thin te-interlaces

We embed \mathring{K}_n , the **complete graph** on n vertices with loops ii , as a convex n -gon in \mathbb{R}^2 :

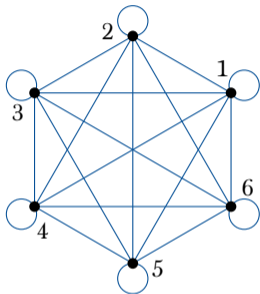

- vertices: $1, \dots, n \in \mathbb{R}^2$,
- edges: line segments $[i, j]$, for $i \neq j$, and circle containing $i = j$ for loops.

Two distinct edges **intersect** if the associated segments or circles meet in \mathbb{R}^2 .

Stellar cycle: subgraph S of K_n such that:

- S covers all the vertices of K_n
- S has n edges
- all the edges pairwise intersect.

Triangulation of thin te-interlaces

We embed \mathring{K}_n , the **complete graph** on n vertices with loops ii , as a convex n -gon in \mathbb{R}^2 :

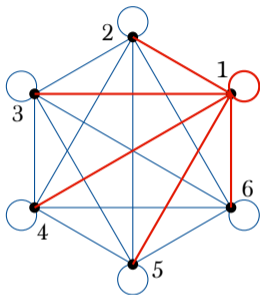

- vertices: $1, \dots, n \in \mathbb{R}^2$,
- edges: line segments $[i, j]$, for $i \neq j$, and circle containing $i = j$ for loops.

Two distinct edges **intersect** if the associated segments or circles meet in \mathbb{R}^2 .

Stellar cycle: subgraph S of K_n such that:

- S covers all the vertices of K_n
- S has n edges
- all the edges pairwise intersect.

Triangulation of thin te-interlaces

We embed \mathring{K}_n , the **complete graph** on n vertices with loops ii , as a convex n -gon in \mathbb{R}^2 :

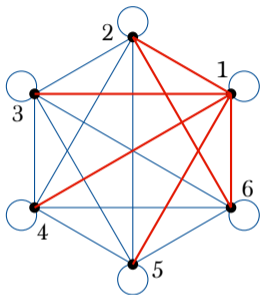

- vertices: $1, \dots, n \in \mathbb{R}^2$,
- edges: line segments $[i, j]$, for $i \neq j$, and circle containing $i = j$ for loops.

Two distinct edges **intersect** if the associated segments or circles meet in \mathbb{R}^2 .

Stellar cycle: subgraph S of K_n such that:

- S covers all the vertices of K_n
- S has n edges
- all the edges pairwise intersect.

Triangulation of thin te-interlaces

We embed \mathring{K}_n , the **complete graph** on n vertices with loops ii , as a convex n -gon in \mathbb{R}^2 :

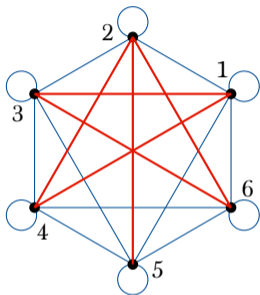

- vertices: $1, \dots, n \in \mathbb{R}^2$,
- edges: line segments $[i, j]$, for $i \neq j$, and circle containing $i = j$ for loops.

Two distinct edges **intersect** if the associated segments or circles meet in \mathbb{R}^2 .

Stellar cycle: subgraph S of K_n such that:

- S covers all the vertices of K_n
- S has n edges
- all the edges pairwise intersect.

Triangulation of thin te-interlaces

We embed \mathring{K}_n , the **complete graph** on n vertices with loops ii , as a convex n -gon in \mathbb{R}^2 :

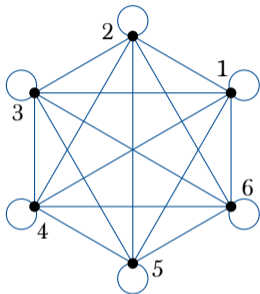

- vertices: $1, \dots, n \in \mathbb{R}^2$,
- edges: line segments $[i, j]$, for $i \neq j$, and circle containing $i = j$ for loops.

Two distinct edges **intersect** if the associated segments or circles meet in \mathbb{R}^2 .

Stellar cycle: subgraph S of K_n such that:

- S covers all the vertices of K_n
- S has n edges
- all the edges pairwise intersect.

Remark

A stellar cycle contains a unique cycle, which is odd.

Triangulation of thin te-interlaces

We embed \mathring{K}_n , the **complete graph** on n vertices with loops ii , as a convex n -gon in \mathbb{R}^2 :

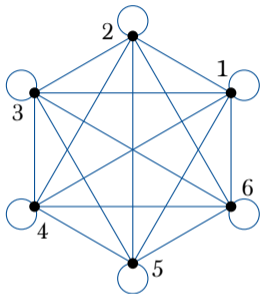

- vertices: $1, \dots, n \in \mathbb{R}^2$,
- edges: line segments $[i, j]$, for $i \neq j$, and circle containing $i = j$ for loops.

Two distinct edges **intersect** if the associated segments or circles meet in \mathbb{R}^2 .

Stellar cycle: subgraph S of K_n such that:

- S covers all the vertices of K_n
- S has n edges
- all the edges pairwise intersect.

Remark

A stellar cycle contains a unique cycle, which is odd.

Correspondence between edges and loops with Hilbert basis elements:

Triangulation of thin te-interlaces

We embed \mathring{K}_n , the **complete graph** on n vertices with loops ii , as a convex n -gon in \mathbb{R}^2 :

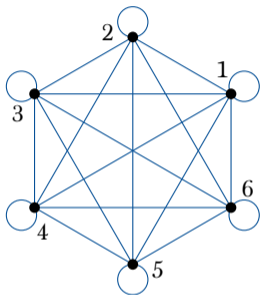

- vertices: $1, \dots, n \in \mathbb{R}^2$,
- edges: line segments $[i, j]$, for $i \neq j$, and circle containing $i = j$ for loops.

Two distinct edges **intersect** if the associated segments or circles meet in \mathbb{R}^2 .

Stellar cycle: subgraph S of K_n such that:

- S covers all the vertices of K_n
- S has n edges
- all the edges pairwise intersect.

Remark

A stellar cycle contains a unique cycle, which is odd.

Correspondence between edges and loops with Hilbert basis elements:

- loop ii : a_i ,

Triangulation of thin te-interlaces

We embed \mathring{K}_n , the **complete graph** on n vertices with loops ii , as a convex n -gon in \mathbb{R}^2 :

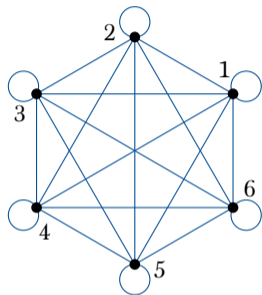

- vertices: $1, \dots, n \in \mathbb{R}^2$,
- edges: line segments $[i, j]$, for $i \neq j$, and circle containing $i = j$ for loops.

Two distinct edges **intersect** if the associated segments or circles meet in \mathbb{R}^2 .

Stellar cycle: subgraph S of K_n such that:

- S covers all the vertices of K_n
- S has n edges
- all the edges pairwise intersect.

Remark

A stellar cycle contains a unique cycle, which is odd.

Correspondence between edges and loops with Hilbert basis elements:

- loop ii : a_i ,
- edge ij : $1/2(a_i + a_j)$.

Triangulation of thin te-interlaces

We embed \mathring{K}_n , the **complete graph** on n vertices with loops ii , as a convex n -gon in \mathbb{R}^2 :

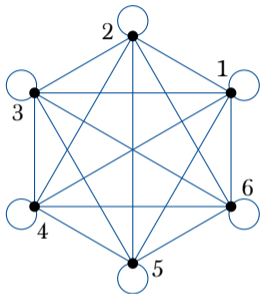

- vertices: $1, \dots, n \in \mathbb{R}^2$,
- edges: line segments $[i, j]$, for $i \neq j$, and circle containing $i = j$ for loops.

Two distinct edges **intersect** if the associated segments or circles meet in \mathbb{R}^2 .

Stellar cycle: subgraph S of K_n such that:

- S covers all the vertices of K_n
- S has n edges
- all the edges pairwise intersect.

Remark

A stellar cycle contains a unique cycle, which is odd.

Correspondence between edges and loops with Hilbert basis elements:

- loop ii : a_i ,
- edge ij : $1/2(a_i + a_j)$.

Fact: The stellar cycles of \mathring{K}_n describe a RUHT of $\text{cone}(A)$, for A a thin te-interlace.

Triangulation of thin te-interlaces

We embed \mathring{K}_n , the **complete graph** on n vertices with loops ii , as a convex n -gon in \mathbb{R}^2 :

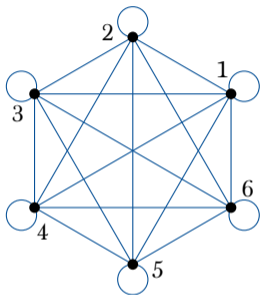

- vertices: $1, \dots, n \in \mathbb{R}^2$,
- edges: line segments $[i, j]$, for $i \neq j$, and circle containing $i = j$ for loops.

Two distinct edges **intersect** if the associated segments or circles meet in \mathbb{R}^2 .

Stellar cycle: subgraph S of K_n such that:

- S covers all the vertices of K_n
- S has n edges
- all the edges pairwise intersect.

Remark

A stellar cycle contains a unique cycle, which is odd.

Correspondence between edges and loops with Hilbert basis elements:

- loop ii : a_i ,
- edge ij : $1/2(a_i + a_j)$.

Fact: The stellar cycles of \mathring{K}_n describe a RUHT of $\text{cone}(A)$, for A a thin te-interlace.

✓ thin te-interlaces

Regular Hilbert triangulation of te-cones and a conjecture

Using Polymake we obtain:

Lemma (Chervet, Grappe, V., 2026)

There is a regular unimodular triangulation of cones generated by thick te-interlaces of size 4 and 6.

Regular Hilbert triangulation of te-cones and a conjecture

Using Polymake we obtain:

Lemma (Chervet, Grappe, V., 2026)

There is a regular unimodular triangulation of cones generated by thick te-interlaces of size 4 and 6.

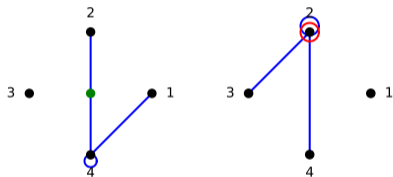

Regular Hilbert triangulation of te-cones and a conjecture

Using Polymake we obtain:

Lemma (Chervet, Grappe, V., 2026)

There is a regular unimodular triangulation of cones generated by thick te-interlaces of size 4 and 6.

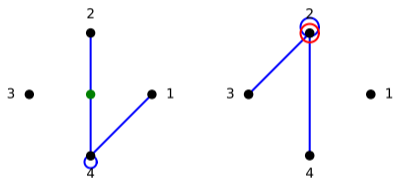

✓ thick te-interlaces, size 4 and 6

Regular Hilbert triangulation of te-cones and a conjecture

Using Polymake we obtain:

Lemma (Chervet, Grappe, V., 2026)

There is a regular unimodular triangulation of cones generated by thick te-interlaces of size 4 and 6.

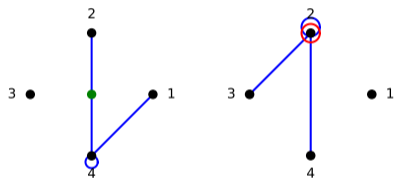

✓ thick te-interlaces, size 4 and 6

Theorem (Chervet, Grappe, V., 2026)

Regular Hilbert triangulation of te-cones and a conjecture

Using Polymake we obtain:

Lemma (Chervet, Grappe, V., 2026)

There is a regular unimodular triangulation of cones generated by thick te-interlaces of size 4 and 6.

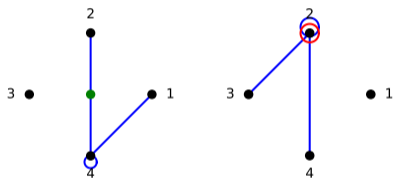

✓ thick te-interlaces, size 4 and 6

Theorem (Chervet, Grappe, V., 2026)

Let A be a linearly independent te-set with no thick te-interlaces of size 8 or more. Then $\text{cone}(A)$ has a regular unimodular Hilbert triangulation.

Regular Hilbert triangulation of te-cones and a conjecture

Using Polymake we obtain:

Lemma (Chervet, Grappe, V., 2026)

There is a regular unimodular triangulation of cones generated by thick te-interlaces of size 4 and 6.

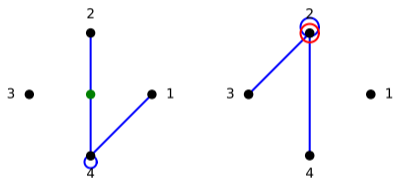

✓ thick te-interlaces, size 4 and 6

Theorem (Chervet, Grappe, V., 2026)

Let A be a linearly independent te-set with no thick te-interlaces of size 8 or more. Then $\text{cone}(A)$ has a **regular unimodular Hilbert triangulation**.

Regular Hilbert triangulation of te-cones and a conjecture

Using Polymake we obtain:

Lemma (Chervet, Grappe, V., 2026)

There is a regular unimodular triangulation of cones generated by thick te-interlaces of size 4 and 6.

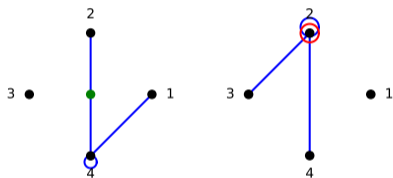

✓ thick te-interlaces, size 4 and 6

Theorem (Chervet, Grappe, V., 2026)

Let A be a linearly independent te-set with no thick te-interlaces of size 8 or more. Then $\text{cone}(A)$ has a regular unimodular Hilbert triangulation.

Note: The same regular triangulation method does not extend to $n \geq 8$.

Regular Hilbert triangulation of te-cones and a conjecture

Using Polymake we obtain:

Lemma (Chervet, Grappe, V., 2026)

There is a regular unimodular triangulation of cones generated by thick te-interlaces of size 4 and 6.

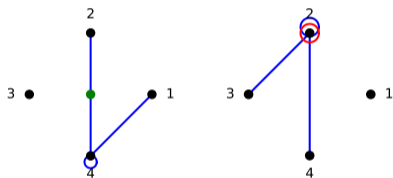

✓ thick te-interlaces, size 4 and 6

Theorem (Chervet, Grappe, V., 2026)

Let A be a linearly independent te-set with no thick te-interlaces of size 8 or more. Then $\text{cone}(A)$ has a **regular unimodular Hilbert triangulation**.

Note: The same regular triangulation method does not extend to $n \geq 8$.

Conjecture (Chervet, Grappe, V., 2026)

Up to resigning, there are only two thick te-interlaces:

$$(r = 4): \begin{bmatrix} 1 & 1 & 1 & 1 \\ 1 & -1 & -1 & 1 \\ 1 & -1 & 1 & -1 \\ 1 & 1 & -1 & -1 \end{bmatrix}, \text{ and}$$

$$(r = 6): \begin{bmatrix} 1 & 1 & 1 & 1 & 1 & 1 \\ 1 & 1 & 1 & 1 & -1 & -1 \\ 1 & 1 & 1 & -1 & -1 & 1 \\ 1 & 1 & -1 & -1 & 1 & 1 \\ 1 & -1 & -1 & 1 & 1 & 1 \\ 1 & -1 & 1 & 1 & 1 & -1 \end{bmatrix}.$$

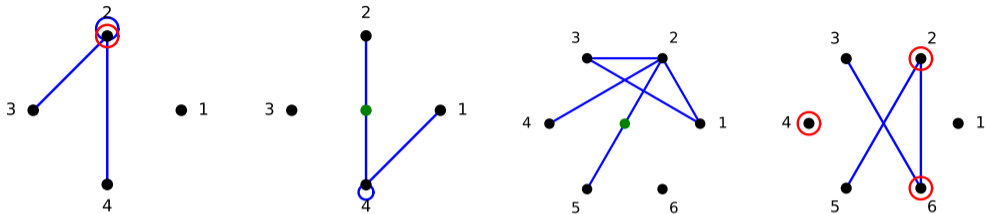

Thank you for listening!

Recap of the results

Type of te-sets	det	examples	Hilbert basis of cone(A)	unim. Hilbert triang.
tu-set totally unimodular	1	$\begin{bmatrix} 1 & 0 & 1 & 0 \\ 0 & 1 & 1 & 0 \\ 0 & 0 & -1 & 0 \end{bmatrix}$	A	trivial: $\{\text{cone}(A)\}$
te-lace not a tu-set, every proper subset is a tu-set	2	$\begin{bmatrix} 1 & 1 & 1 & 0 \\ 1 & -1 & 1 & 0 \\ 1 & 1 & 0 & -1 \\ 1 & 0 & 1 & -1 \\ 0 & 1 & 1 & 0 \end{bmatrix}$	$A \cup \{h = \frac{1}{2} \sum_i a_i\}$	stellar triangulation: $\{\text{cone}(\{h\} \cup \{a_j\}_{j \neq i})\}_i$ 
te-interlace not a tu-set, every pair forms a te-lace	thin: 2^{r-1}	$\begin{bmatrix} 1 & 1 & 0 & 1 \\ 1 & -1 & 0 & 1 \\ 1 & 1 & 0 & -1 \end{bmatrix}$	$A \cup \{\frac{1}{2}(a_i + a_j)\}_{i \neq j}$	triangulation of the second hypersimplex
	thick: 2^r	$\begin{bmatrix} 1 & 1 & 1 & 1 \\ 1 & 1 & -1 & -1 \\ 1 & -1 & -1 & 1 \\ 1 & -1 & 1 & -1 \end{bmatrix}$	$A \cup \{\frac{1}{2}(a_i + a_j)\}_{i \neq j} \cup H$ for $H = \begin{cases} \{\frac{1}{4} \sum_i a_i\}, \text{ or} \\ \{\frac{3}{4} a_i + \frac{1}{4} \sum_{j \neq i} a_j\}_i. \end{cases}$	only for $r = 4$ and 6

On the conjecture

Let A be a 0,1 matrix and i a row index of A . The **row- i complement** $A_{[i]}$ of A is:

$$\begin{cases} A_i, & \text{if } i' = i, \\ A_{i'} + A_i \pmod{2}, & \text{otherwise.} \end{cases}$$

Same for columns j : $A^{[j]}$.

On the conjecture

Let A be a 0,1 matrix and i a row index of A . The **row- i complement** $A_{[i]}$ of A is:

$$\begin{cases} A_i, & \text{if } i' = i, \\ A_{i'} + A_i \pmod{2}, & \text{otherwise.} \end{cases}$$

Same for columns j : $A^{[j]}$.

Example:

$$I_4 = \begin{bmatrix} 1 & 0 & 0 & 0 \\ 0 & 1 & 0 & 0 \\ 0 & 0 & 1 & 0 \\ 0 & 0 & 0 & 1 \end{bmatrix}, (I_4)_{[1]} = \begin{bmatrix} 1 & 0 & 0 & 0 \\ 1 & 1 & 0 & 0 \\ 1 & 0 & 1 & 0 \\ 1 & 0 & 0 & 1 \end{bmatrix},$$

$$(I_4)_{[1]}^{[1]} = \begin{bmatrix} 1 & 1 & 1 & 1 \\ 1 & 0 & 1 & 1 \\ 1 & 1 & 0 & 1 \\ 1 & 1 & 1 & 0 \end{bmatrix}.$$

On the conjecture

Let A be a 0,1 matrix and i a row index of A . The **row- i complement** $A_{[i]}$ of A is:

$$\begin{cases} A_i, & \text{if } i' = i, \\ A_{i'} + A_i \pmod{2}, & \text{otherwise.} \end{cases}$$

Same for columns j : $A^{[j]}$.

Example:

$$I_4 = \begin{bmatrix} 1 & 0 & 0 & 0 \\ 0 & 1 & 0 & 0 \\ 0 & 0 & 1 & 0 \\ 0 & 0 & 0 & 1 \end{bmatrix}, (I_4)_{[1]} = \begin{bmatrix} 1 & 0 & 0 & 0 \\ 1 & 1 & 0 & 0 \\ 1 & 0 & 1 & 0 \\ 1 & 0 & 0 & 1 \end{bmatrix},$$

$$(I_4)_{[1]}^{[1]} = \begin{bmatrix} 1 & 1 & 1 & 1 \\ 1 & 0 & 1 & 1 \\ 1 & 1 & 0 & 1 \\ 1 & 1 & 1 & 0 \end{bmatrix}.$$

A matrix is **minimally non-TU** if it is not TU but all its proper submatrices are TU.

On the conjecture

Let A be a 0,1 matrix and i a row index of A . The **row- i complement** $A_{[i]}$ of A is:

$$\begin{cases} A_i, & \text{if } i' = i, \\ A_{i'} + A_i \pmod{2}, & \text{otherwise.} \end{cases}$$

Same for columns j : $A^{[j]}$.

Example:

$$I_4 = \begin{bmatrix} 1 & 0 & 0 & 0 \\ 0 & 1 & 0 & 0 \\ 0 & 0 & 1 & 0 \\ 0 & 0 & 0 & 1 \end{bmatrix}, (I_4)_{[1]} = \begin{bmatrix} 1 & 0 & 0 & 0 \\ 1 & 1 & 0 & 0 \\ 1 & 0 & 1 & 0 \\ 1 & 0 & 0 & 1 \end{bmatrix},$$

$$(I_4)_{[1]}^{[1]} = \begin{bmatrix} 1 & 1 & 1 & 1 \\ 1 & 0 & 1 & 1 \\ 1 & 1 & 0 & 1 \\ 1 & 1 & 1 & 0 \end{bmatrix}.$$

A matrix is **minimally non-TU** if it is not TU but all its proper submatrices are TU.

A matrix is **complement minimally non-TU** all its complement matrices are minimally non-TU.

On the conjecture

Let A be a 0,1 matrix and i a row index of A . The **row- i complement** $A_{[i]}$ of A is:

$$\begin{cases} A_i, & \text{if } i' = i, \\ A_{i'} + A_i \pmod{2}, & \text{otherwise.} \end{cases}$$

Same for columns j : $A^{[j]}$.

Example:

$$I_4 = \begin{bmatrix} 1 & 0 & 0 & 0 \\ 0 & 1 & 0 & 0 \\ 0 & 0 & 1 & 0 \\ 0 & 0 & 0 & 1 \end{bmatrix}, (I_4)_{[1]} = \begin{bmatrix} 1 & 0 & 0 & 0 \\ 1 & 1 & 0 & 0 \\ 1 & 0 & 1 & 0 \\ 1 & 0 & 0 & 1 \end{bmatrix},$$

$$(I_4)_{[1]}^{[1]} = \begin{bmatrix} 1 & 1 & 1 & 1 \\ 1 & 0 & 1 & 1 \\ 1 & 1 & 0 & 1 \\ 1 & 1 & 1 & 0 \end{bmatrix}.$$

A matrix is **minimally non-TU** if it is not TU but all its proper submatrices are TU.

A matrix is **complement minimally non-TU** all its complement matrices are minimally non-TU.

Conjecture*

The only complement minimally non-TU matrices are complements of:

$$\begin{bmatrix} 1 & 0 & 1 \\ 1 & 1 & 0 \\ 0 & 1 & 1 \end{bmatrix} \text{ and } \begin{bmatrix} 1 & 0 & 0 & 0 & 1 \\ 1 & 1 & 0 & 0 & 0 \\ 0 & 1 & 1 & 0 & 0 \\ 0 & 0 & 1 & 1 & 0 \\ 0 & 0 & 0 & 1 & 1 \end{bmatrix}.$$